



POMPE PER ACQUA
WATER PUMPS - POMPES A EAU - WASSERPUMPEN

COMEX

SINCE 1975



MANAGEMENT SYSTEM CERTIFICATE

Certificate no.:
181816-2015-AQ-ITA-ACCREDIA

Initial certification date:
29 June 2015

Valid:
30 June 2024 – 29 June 2027

This is to certify that the management system of

COMEX S.r.l.

Via delle Industrie, 42 - 31057 Silea (TV) - Italy

has been found to conform to the Quality Management System standard:

ISO 9001:2015

This certificate is valid for the following scope:

Design, manufacture, sale, trade and servicing of electropumps and relevant spare parts (IAF 18)

Place and date:
Vimercate (MB), 02 May 2024



SGQ N° 002 A
SGA N° 003 D
SGE N° 007 M
SGR N° 004 F

EMAS N° 009 P
PR2 N° 003 B
PR2 N° 004 C
SG3 N° 002 G

Membro di UNILIA per gli schemi di accreditamento
SGQ, SGA, PR2, PR3, SGQ, SGA, SGE, SGR, SG3, EMAS
per gli schemi di accreditamento SGQ, SGA, SG3, ISM
e PR2 e c. MIRA, ILAC per gli schemi di accreditamento
LAE, MLO, LAI e ISP

For the issuing office:
DNV - Business Assurance
Via Energy Park, 14, - 20871 Vimercate (MB) - Italy



Claudia Baroncini
Management Representative



POMPE PER ACQUA WATER PUMPS

La nostra lunga storia inizia nel 1975, anno in cui furono progettati i primi modelli di pompe COMEX. Fin da allora siamo stati guidati dalla volontà di costruire prodotti di alta qualità per soddisfare le diverse esigenze dei clienti. Per ottenere ciò abbiamo sempre dato la massima importanza ad una progettazione all'avanguardia, all'attenta scelta dei componenti e ai severi controlli qualitativi nel rispetto della certificazione ISO 9001.

Our long history begins back to 1975, when the first models of COMEX pumps have been projected. Ever since we have been driven by the will to manufacture high quality products to satisfy the different requirements of the customers.

To get that we have always given the utmost importance to a state of the art engineering, to the selection of the best components and to meticulous quality controls in compliance with ISO 9001 Certification.



Le prestazioni riportate nel catalogo sono state definite testando i nostri prodotti con acqua pulita. Le prestazioni delle pompe di superficie si riferiscono ad un funzionamento sotto battente.

The performances shown in the catalogue have been defined testing our products with clean water. The performances of the surface pumps refer to a working with positive suction head.

POMPE SOMMERGIBILI PER LIQUAMI

SUBMERSIBLE PUMPS FOR SEWAGE WATER

VORTEX 50





VORTEX 75



 Pompe sommergibili per acque piovane, scarichi di lavatrici e lavastoviglie, fosse biologiche, ecc.
Robusta costruzione. Coperchio, cassa e supporto in ghisa. Girante tipo “vortex” aperta ed arretrata in ghisa. Albero in acciaio inox temperato. Motore a bagno d’olio con protezione termica incorporata. Tenuta meccanica in allumina / grafite. Cavo di alimentazione di 10 metri in neoprene H07RNF per il modello VORTEX 50, in H07RN8-F per il modello VORTEX 75. Protezione IP 68. Isolamento classe F. Temperatura massima del liquido da pompare 40 °C; pH: 6 – 10; massima densità < 1100 kg/m³.

 Submersible pumps, based on the vortex principle, suitable for the pumping of rain and sewage water.
Heavy duty construction. Pump body, cover and support in cast iron. Back and open impeller “vortex” type in cast iron. Oil bathed motor with built-in motor protector. Shaft in stainless steel. Mechanical seal in alumina/graphite. 10 metres supply cable H07RNF for the model VORTEX 50, H07RN8-F for the model VORTEX 75.
Protection class IP 68. Insulation class F. Max. temperature of pumped liquid 104 °F (40 °C); pH: 6 – 10; max. density < 1100 kg/m³.

 Pompes submersibles à tourbillon indiquées pour eaux chargées, eaux domestiques, vide-caves, etc.
Construction robuste. Corps de pompe, couvercle et support en fonte. Roue “vortex” semi-ouverte en fonte. Moteur à bain d’huile avec protection thermique. Arbre en acier inox. Garniture mécanique en alumine/graphite. Câble électrique H07RNF de 10 mètres sur le modèle VORTEX 50, H07RN8-F sur le modèle VORTEX 75.
Protection IP 68. Isolation classe F. Température max. du liquide pompé 40 °C; pH: 6 – 10; densité max. < 1100 kg/m³.

 Abwasser-Tauchpumpen für Schmutzwasser mit Festkörper.
Hergestellt aus hochwertigen und widerstandsfähigen Materialien. Pumpengehäuse und “Vortex” Laufrad aus Grauguß. Antriebswelle aus rostfreiem Stahl. Ölgefüllter Tauchmotor mit thermischen Motorschutz. Gleitringdichtung aus Aluminiumoxyd/Graphit. 10 Meter Kabel H07RNF beim Modell VORTEX 50, 10 Meter Kabel H07RN8-F beim Modell VORTEX 75.
IP 68 Schutz. Isol. Klasse F. Max. Temperatur der Flüssigkeit 40 °C; pH: 6 – 10; max. Dichte < 1100 kg/m³.

Modello Model Modèle Modell	Potenza Power Puissance Pferdestärke		Tensione Voltage Bobinage Spannung V-Hz-ph	A	Prevalenza - Head - Hauteur - Förderhöhe (m)								
	HP	kW			1	2	3	4	5	6	7	8	
	Portata - Capacity - Débit - Fördermenge (l/min)												
VORTEX 50	0,50	0,37	230-50-1	3,0	180	155	129	100	68	37			
VORTEX 75	0,75	0,55	230-50-1	4,2	225	205	188	165	139	105	63	4	

*On request other voltages are available

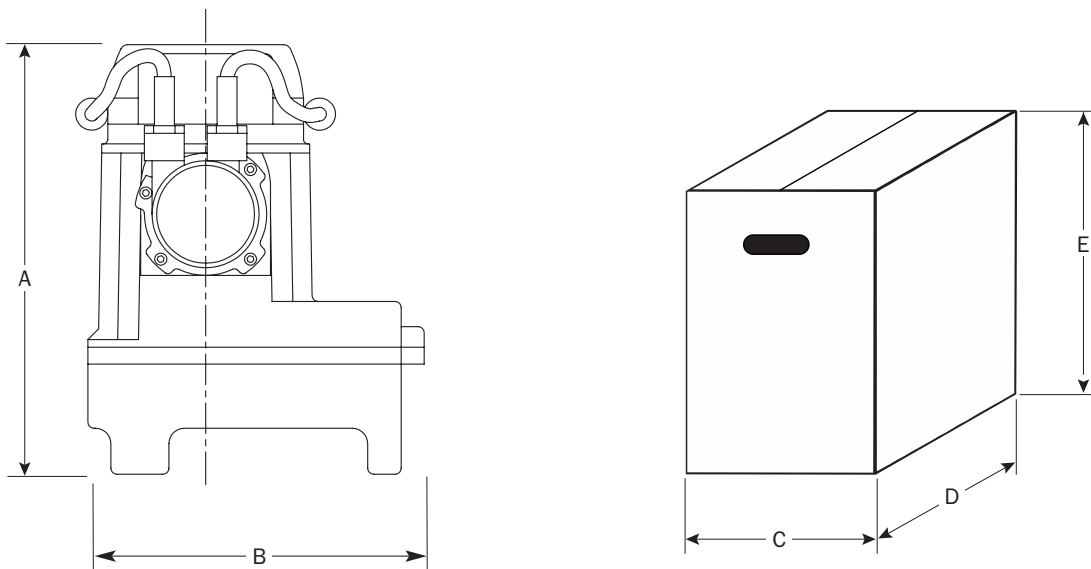
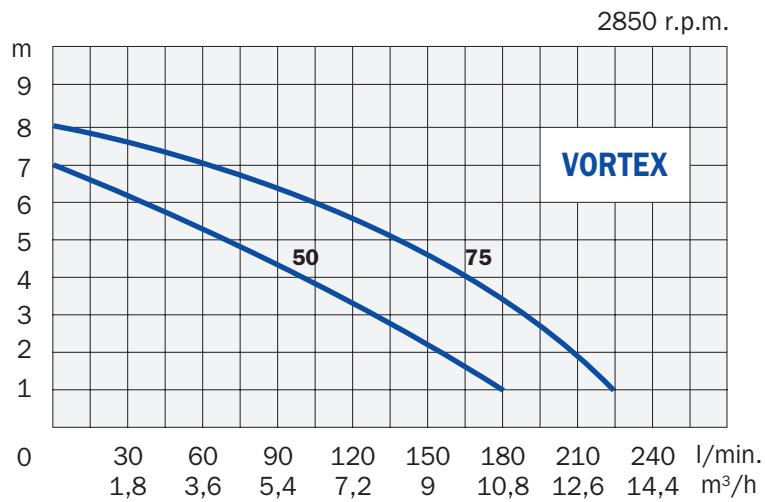

Modello Model Modèle Modell	Mandata Discharge Refoulement Druck-Seite	Corpi solidi Solid parts Corps solides Festkörper mm	Dimensioni - Dimensions - Masstabelle mm					Peso Weight Poids Gewicht kg
			A	B	C	D	E	
			VORTEX 50	1"1/4 - DN 32 horizontal	25	328	141	
VORTEX 75	1"1/4 - DN 32 vertical	30	281	220	230	200	470	17

POMPE SOMMERGIBILI PER LIQUAMI

SUBMERSIBLE PUMPS FOR SEWAGE WATER



VORTEX 100 - 140

-  Pompe sommergibili per liquami ed acque piovane. Robusta costruzione. Coperchio, cassa e supporto in ghisa. Girante aperta ed arretrata in ghisa di tipo “vortex”. Albero in acciaio inox temperato. Motore a bagno d’olio con protezione termica incorporata. Tenuta meccanica in carburo di silicio ed anello di tenuta. Cavo di alimentazione di 10 metri in neoprene H07RN8-F.
Protezione IP 68. Isolamento classe F. Temperatura massima del liquido da pompare 40 °C; pH: 6 – 10; massima densità < 1100 kg/m³.

-  Submersible pumps for sewage and rain water. Heavy duty construction. Pump body, cover and support in cast iron. Back and open impeller “vortex” type in cast iron. Oil bathed motor with built-in motor protector. Shaft in stainless steel. Mechanical seal in silicon carbide and lip seal ring. 10 metres supply cable H07RN8-F.
Protection class IP 68. Insulation class F. Max. temperature of pumped liquid 104 °F (40 °C); pH: 6 – 10; max. density < 1100 kg/m³.

-  Pompes submersibles à tourbillon pour eaux chargées et vide-caves. Construction robuste. Corps de pompe, couvercle et support en fonte. Roue “vortex” semi-ouverte en fonte. Moteur à bain d’huile avec protection thermique. Arbre en acier inox. Garniture mécanique en carbure de silicium et bague d’étanchéité à lèvres. Câble électrique H07RN8-F de 10 mètres.
Protection IP 68. Isolation classe F. Température max. du liquide pompé 40 °C; pH: 6 – 10; densité max. < 1100 kg/m³.

-  Abwasser-Tauchpumpen hergestellt aus hochwertigen und widerstandsfähigen Materialien. Pumpengehäuse und “Vortex” Laufrad aus Grauguß. Antriebswelle aus rostfreiem Stahl. Ölgefüllter Tauchmotor mit thermischen Motorschutz. Gleitringdichtung aus Siliziumkarbid und Öldichtungsring. 10 Meter Kabel H07RN8-F.
IP 68 Schutz. Isol. Klasse F. Max. Temperatur der Flüssigkeit 40 °C; pH: 6 – 10; max. Dichte < 1100 kg/m³.

Modello Model Modèle Modell	Potenza Power Puissance Pferdestärke		Tensione Voltage Bobinage Spannung V-Hz-ph	A	Prevalenza - Head - Hauteur - Förderhöhe (m)								
	HP	kW			1	2	3	4	5	6	7	8	9
	Portata - Capacity - Débit - Fördermenge (l/min)												
VORTEX 100	1,0	0,75	230-50-1	6,2	350	325	298	262	227	188	134	78	
			400-50-3	2,8									
VORTEX 140	1,4	1,04	230-50-1	7,6	450	416	376	340	300	248	190	125	38
			400-50-3	3,0									

*On request other voltages are available

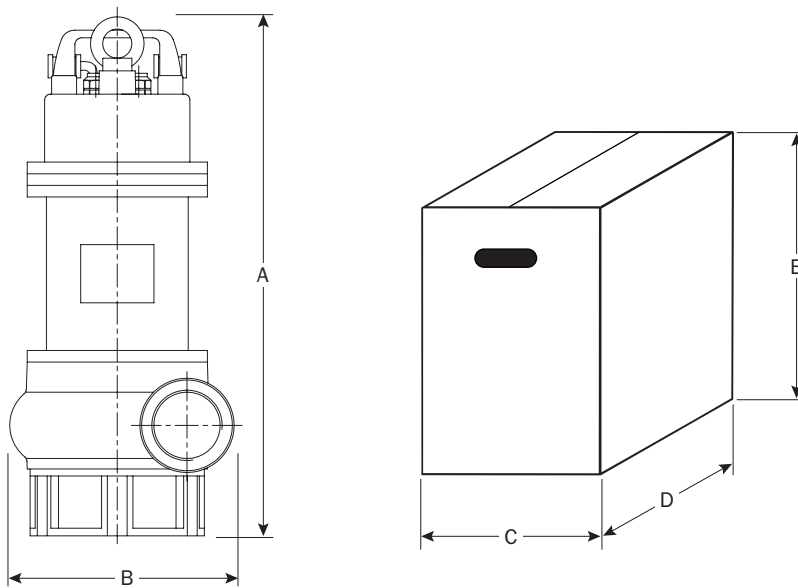
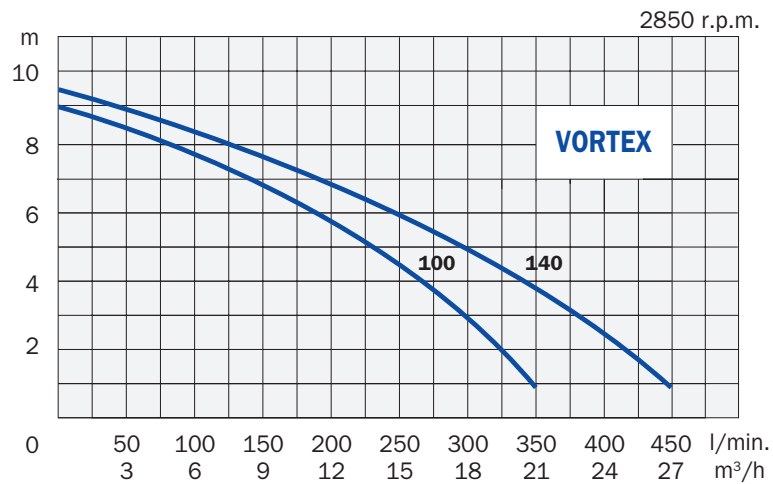

Modello Model Modèle Modell	Mandata Discharge Refoulement Druck-Seite	Corpi solidi Solid parts Corps solides Festkörper	Dimensioni - Dimensions - Masstabelle					Peso Weight Poids Gewicht
			mm					
			A	B	C	D	E	
VORTEX 100	2" - DN 50 horizontal	45	440	194	230	200	470	25
VORTEX 140	2" - DN 50 horizontal	45	440	194	230	200	470	27

POMPE SOMMERGIBILI PER LIQUAMI

SUBMERSIBLE PUMPS FOR SEWAGE WATER

VORTEX 150 - 200



VORTEX 300



PIEDE DI ACCOPIAMENTO
AUTOMATIC COUPLING FOOT

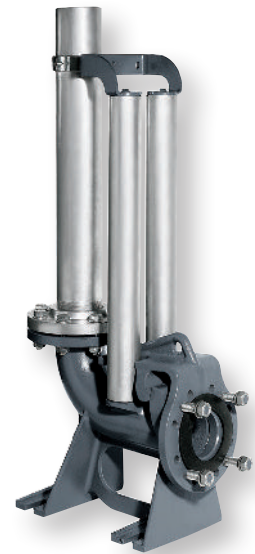

 Pompe sommergibili adatte alla movimentazione di acque sporche con corpi solidi in sospensione. Particolarmente indicate per acque di scarichi civili, per impianti di depurazione e per uso zootecnico.

Robusta costruzione. Coperchio, cassa statore, corpo di mandata e supporto in ghisa. Girante aperta ed arretrata di tipo "vortex" in ghisa. Albero in acciaio inox temperato. Motore a bagno d'olio. Doppia tenuta meccanica in carburo di silicio in camera d'olio. Cavo di alimentazione di 10 metri in neoprene H07RN8-F. Tensione monofase con condensatore e protezione termica incorporati; tensione trifase con protezione a cura dell'utente.

Protezione IP 68. Isolamento classe F. Temperatura massima del liquido da pompare 40 °C; pH: 6 – 10; massima densità < 1100 kg/m³.

 Submersible pumps, based on the vortex principle, suitable for the pumping of sewage water with solid parts. Particularly recommended for domestic waste water plants, for industrial water treatment and for a lot of uses in the agriculture and in the zootechnic fields.

Heavy duty construction. Pump housing in cast iron. Back and open impeller "vortex" type in cast iron. Oil bathed motor. Shaft in stainless steel. Double mechanical seal in silicon carbide in oil chamber. 10 metres supply cable H07RN8-F. Single-phase voltage with built-in capacitor and motor protector. The three-phase pump must be protected by a fused remote isolator switch.

Protection class IP 68. Insulation class F. Max. temperature of pumped liquid 104 °F (40 °C); pH: 6 – 10; max. density < 1100 kg/m³.

 Pompes submersibles à tourbillon indiquées pour eaux chargées avec corps solides. Particulièrement conseillées pour eaux résiduaires, pour vide-caves, pour traitement des eaux industrielles, pour plusieurs emplois dans le domaine agricole et zootechnique. Construction robuste. Couvercle, corps de pompe, corps de refoulement et support en fonte. Roue "vortex" semi-ouverte en fonte. Arbre en acier inox. Moteur à bain d'huile. Double garniture mécanique en carbure de silicium en chambre d'huile. Câble électrique H07RN8-F de 10 mètres. Bobinage monophasé avec condensateur et protection thermique incorporés; bobinage triphasé avec protection par l'usager.

Protection IP 68. Isolation classe F. Température max. du liquide pompé 40 °C; pH: 6 – 10; densité max. < 1100 kg/m³.

 Abwasser-Tauchpumpen für Schmutzwasser mit Festkörper. Hergestellt aus hochwertigen und widerstandsfähigen Materialien. Pumpengehäuse und "Vortex" Laufrad aus Grauguß. Antriebswelle aus rostfreiem Stahl. Ölgefüllter Tauchmotor. Ölgekühlte Doppel-Gleitringdichtung aus Siliziumcarbid. 10 Meter Kabel H07RN8-F. Einphasenspannung mit Kondensator und thermischen Motorschutz; Dreiphasenspannung, Motorvollschutz nach Benutzersorge.

IP 68 Schutz. Isol. Klasse F. Max. Temperatur der Flüssigkeit 40 °C; pH: 6 – 10; max. Dichte < 1100 kg/m³.

Modello Model Modèle Modell	Potenza Power Puissance Pferdestärke		Tensione Voltage Bobinage Spannung V-Hz-ph	A	Prevalenza - Head - Hauteur - Förderhöhe (m)					
	HP	kW			2	4	6	8	10	12
					Portata - Capacity - Débit - Fördermenge (l/min)					
VORTEX 150	1,5	1,1	230-50-1	9,5	450	350	245	110		
			400-50-3	3,5						
VORTEX 200	2	1,5	230-50-1	10,8	550	480	370	245	100	
			400-50-3	5,0						
VORTEX 300	3	2,2	400-50-3	6,5	700	620	520	390	250	70

*On request other voltages are available

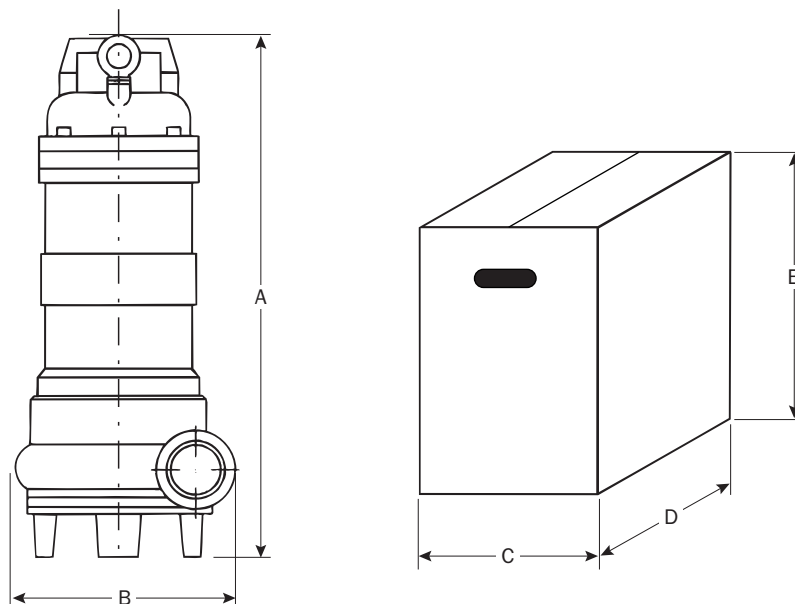
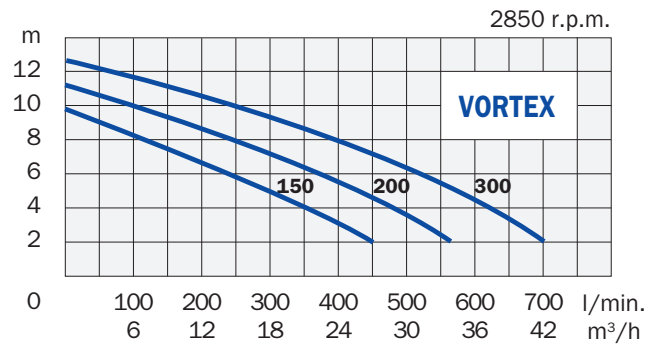

Modello Model Modèle Modell	Mandata Discharge Refoulement Druck-Seite	Corpi solidi Solid parts Corps solides Festkörper	Dimensioni - Dimensions - Masstabelle					Peso Weight Poids Gewicht
			mm					
			A	B	C	D	E	
VORTEX 150	2" - DN 50 horizontal	50	520	220	295	255	550	33
VORTEX 200	2" - DN 50 horizontal	50	520	220	295	255	550	34
VORTEX 300	3" - DN 80 horizontal	55	525	235	295	255	550	39

NEW

POMPE PER ACQUA SPORCA AD ALTA PREVALENZA SEWAGE WATER PUMPS WITH HIGH HEAD



VORTEX E / 23

 Pompe sommergibili adatte alla movimentazione di acque sporche e reflui industriali contenenti corpi solidi o filamentosi. Robusta costruzione. Coperchio, corpo di mandata e supporto in ghisa. Cassa statore in ghisa nel modello VORTEX 1000 E, in acciaio AISI 304 negli altri modelli. Girante monocanale nel modello VORTEX 1000 E, aperta ed arretrata di tipo “vortex” in ghisa negli altri modelli. Doppia tenuta meccanica in carburo di silicio in camera d’olio. Cavo di alimentazione di 10 metri in neoprene H07RNF. Protezione a cura dell’utente. IP 68. Isolamento classe F. Temperatura massima del liquido da pompare 40 °C; pH: 6 – 10; massima densità < 1100 kg/m³.

 Submersible pumps suitable for the pumping of dirty water and industrial effluents containing solid or fibrous parts. Heavy duty construction. Cover, discharge body and footing in cast-iron. Motor case in cast-iron on the model VORTEX 1000 E, in stainless steel AISI 304 on the other models. Mono-channel impeller on the model VORTEX 1000 E, back and open impeller “vortex” type in cast-iron on the other models. Double mechanical seal in silicon carbide in oil chamber. 10 meters supply cable H07RNF. The pump must be protected by a fused remote isolator switch. IP 68. Insulation class F. Max. temperature of pumped liquid 104 °F (40 °C); pH: 6 – 10; max. density: < 1100 kg/m³.

 Pompes submersibles indiquées pour eaux sales avec corps solides ou filamenteux. Particulièrement conseillées pour eaux résiduaires et pour traitement des eaux industrielles. Construction robuste. Couvercle, corps de refoulement et support en fonte. Corps de moteur en fonte dans le modèle VORTEX 1000 E, en acier AISI 304 dans les autres modèles. Roue monocanal dans le modèle VORTEX 1000 E, type « vortex » en fonte dans les autres modèles. Double garniture mécanique en carbure de silicium en chambre d’huile. Câble électrique H07RNF de 10 mètres. Protection par l’usager. Protection IP 68. Isolation classe F. Température max. du liquide pompé 40 °C; pH: 6 – 10; densité max. < 1100 kg/m³.

 Abwasser-Tauchpumpen für Schmutzwasser mit Festkörper. Hergestellt aus hochwertigen und widerstandsfähigen Materialien. Pumpendeckel, Pumpenauslassgehäuse und Sockel aus Grauguss. Statorgehäuse aus Grauguss beim Modell VORTEX 1000 E, aus AISI 304-Stahl bei den anderen Modellen. Einkanaliges Laufrad beim Modell VORTEX 1000 E, “Vortex” Wirbelauftrad aus Grauguss bei den anderen Modellen. “Vortex” Wirbelauftrad aus Grauguss Ölgekühlte Doppel-Gleitringdichtung aus Siliziumkarbid. 10 Meter Kabel H07RNF. Motorvollschutz nach Benutzersorge. IP 68 Schutz. Isol. Klasse F. Max. Temperatur der Flüssigkeit: 40 °C; pH: 6 – 10; max. Dichte < 1100 kg/m³.

Modello Model	Potenza Power		Tensione Voltage	I _n A	Prevalenza - Head (m)								
	HP	kW			4	8	10	12	16	20	24	28	32
					Portata - Capacity (l/min)								
VORTEX 400 E / 23	4.0	3.0	400/50/3	4,6	800	590	455	320					
VORTEX 550 E / 23	5.5	4.0	400/50/3	7,6	998	815	704	600	330				
VORTEX 750 E / 23	7.5	5.5	400/50/3	11,0	1310	1225	1160	1085	855	560	105		
VORTEX 1000 E / 23	10.0	7.5	400/50/3	16,3	2220	2010	1900	1780	1515	1250	950	600	250

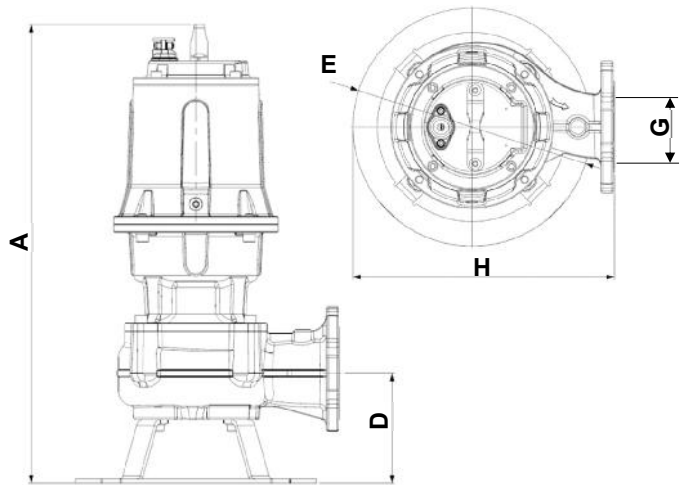
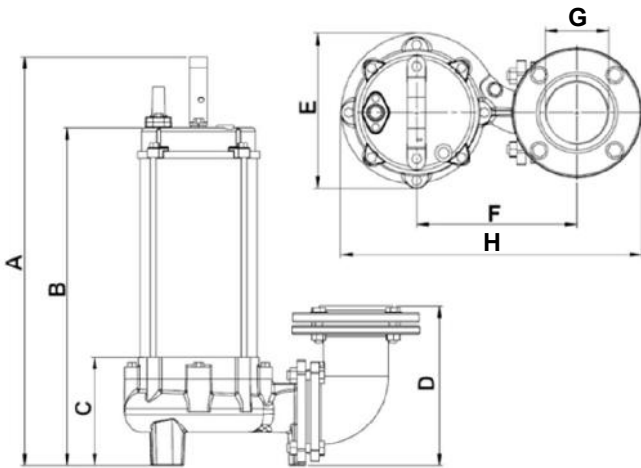
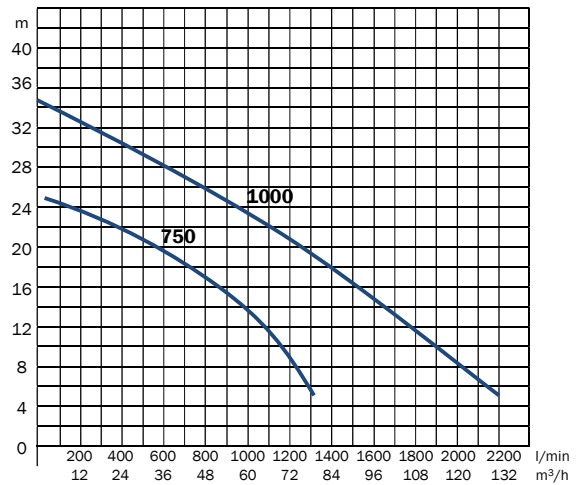
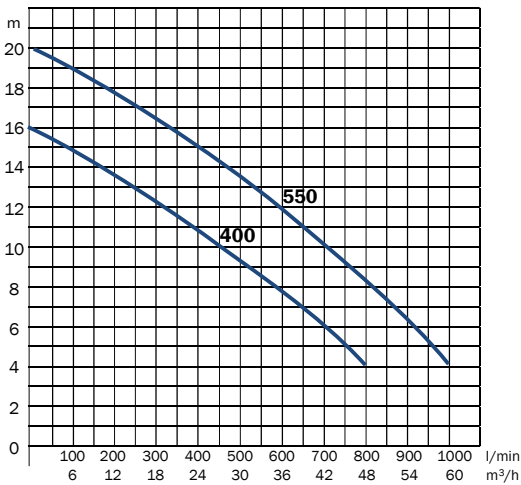

Modello Model	Mandata Discharge	Corpi solidi Solid parts	Dimensioni Dimensions								Peso Weight
			mm								
		mm	A	B	C	D	E	F	G	H	kg
VORTEX 400 E / 23	3" - DN80 vertical	45	530	454	165	165	218	241	3"	401	37
VORTEX 550 E / 23	3" - DN80 vertical	55	576	476	153	225	215	222	3"	417	47
VORTEX 750 E / 23	3" - DN80 vertical	55	619	519	148	250	237	256	3"	468	53
VORTEX 1000 E / 23	3" - DN80 horizontal	55	685	-	-	164	360	-	3"	395	95

POMPE SOMMERGIBILI PER LIQUAMI - 4 POLI - DN 100

SUBMERSIBLE PUMPS FOR SEWAGE WATER - 4 POLES - DN 100

VORTEX 400-750/23



 Pompe sommergibili adatte alla movimentazione di acque sporche e reflui industriali contenenti corpi solidi o filamentosi, fognature urbane e liquami di stalla. Motore 4 poli, 1450 rpm. Robusta costruzione. Coperchio, cassa statore e corpo mandata in ghisa. Girante monocanale in ghisa. Albero in acciaio inox AISI 420. Doppia tenuta meccanica in camera d'olio: inferiore in carburo di silicio, superiore in ceramica/grafite. Cavo alimentazione di 10 metri in neoprene H07RN8-F. Sonda rilevazione umidità in camera tenute e sonda temperatura in avvolgimento. Isolamento classe F. IP 68. Temperatura massima liquido da pompare 40 °C; pH: 6 - 10; massima densità 1100 kg/m³.

 Submersible pumps suitable for sewage effluents containing solid or fibrous parts in industrial and agricultural applications and in waste water treatment plants. 4 poles motor, 1450 rpm. Heavy duty construction. Pump cover, motor housing and discharge body in cast-iron. Single channel impeller in cast-iron. Shaft in stainless steel AISI 420. Double mechanical seal in oil chamber: the upper in ceramic/graphite, the lower in silicon carbide. 10 meters supply cable in neoprene H07RN8-F. Humidity detection probe in mechanical seal chamber and winding temperature probe. Insulation class F. IP 68. Max. temperature of pumped liquid 104 °F (40 °C); pH: 6 - 10; max. density 1100 kg/m³.

 Pompes submersibles indiquées pour eaux chargées avec corps solides ou fibreux. Particulièrement conseillées pour eaux résiduaires, pour traitement des eaux industrielles et d'autres emplois dans le domaine agricole et zootechnique. Moteur 4 pôles, 1450 rpm. Construction robuste. Couvercle, corps de pompe et corps de refoulement en fonte. Roue monocal en fonte. Arbre en acier inox AISI 420. Double garniture mécanique en chambre d'huile: la supérieure est en céramique/graphite, celle inférieure en carbure de silicium. Câble électrique en néoprène de 10 mètres H07RN8-F. Sonde de détection d'humidité dans la chambre de la garniture mécanique et sonde de température dans le bobinage du moteur. Isolation classe F. IP 68. Température max. du liquide pompé: 40 °C; pH: 6 - 10; densité max. 1100 kg/m³.

 Tauchpumpen, die für die Förderung von Schmutzwasser und Industrieabwässern mit festen oder fadenförmigen Bestandteilen, städtischen Abwässern und Stallabwässern geeignet sind. 4-poliger Motor, 1450 U/min. Robuste Konstruktion. Abdeckung, Statorgehäuse und Förderkörper aus Grauguß. Einkanaliges Laufrad aus Grauguß. Antriebswelle aus rostfreiem Stahl AISI 420. Ölgekühlte Doppel-Gleitringdichtung: Oberdichtung aus Keramik/Graphit, Unterdichtung aus Siliziumkarbid. 10 Meter Neopren-Stromkabel H07RN8-F. Feuchtigkeitserkennungssonde in der Gleitringdichtungskammer und Motorwicklungstemperaturerkennungssonde. Schutzklasse F. IP 68 Schutz. Maximale Temperatur der zu pumpenden Flüssigkeit 40 °C; pH-Wert: 6 - 10; maximale Dichte 1100 kg/m³.

Modello Model	Potenza Power		Tensione Voltage	rpm	I _n A	Prevalenza - Head (m)						
	HP	kW				4	6	8	10	12	14	16
	Portata - Capacity (l/min)											
VORTEX 400 / 23	4.0	3.0	400/50/3	1450	7,1	1700	1440	1150	830	450		
VORTEX 550 / 23	5.5	4.0	400/50/3	1450	9,4	2440	2120	1800	1410	1000	540	
VORTEX 750 / 23	7.5	5.5	400/50/3	1450	11,8	2820	2500	2170	1800	1410	1000	550

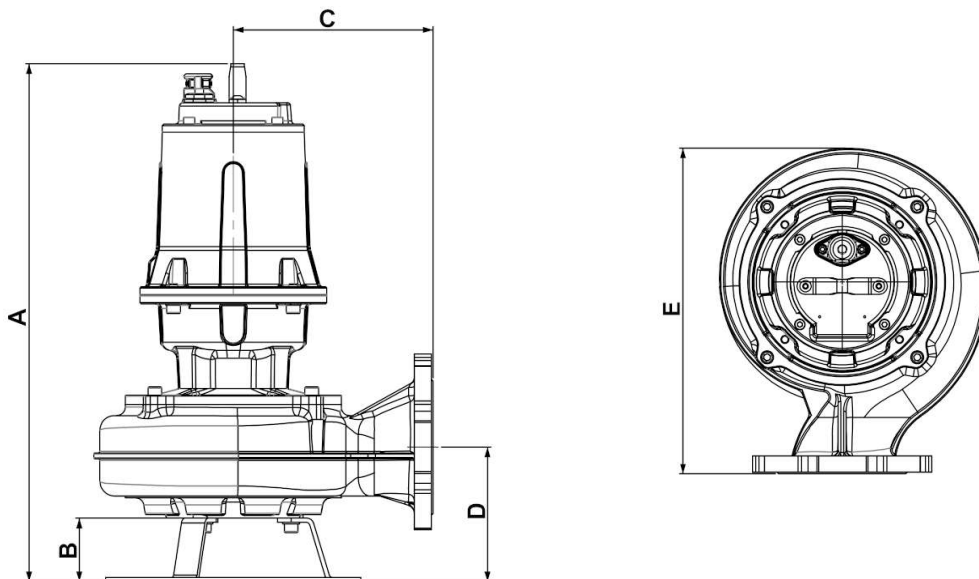
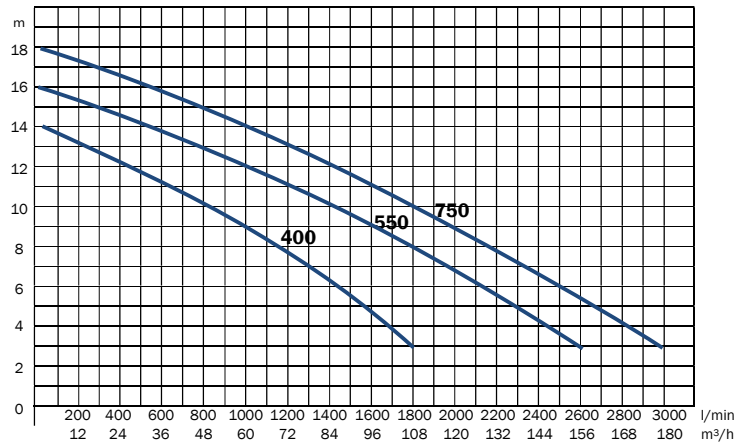

Modello Model	Mandata Discharge	Corpi solidi Solid parts	Dimensioni Dimensions					Peso Weight
			mm	A	B	C	D	
VORTEX 400 / 23	4"- DN 100 horizontal	85	611	75	235	159	399	70
VORTEX 550 / 23	4"- DN 100 horizontal	90	722	95	275	198	462	96
VORTEX 750 / 23	4"- DN 100 horizontal	90	722	95	275	198	462	103

POMPE SOMMERGIBILI PER LIQUAMI - DN 150

SUBMERSIBLE PUMPS FOR SEWAGE WATER - DN 150

VORTEX 1000 - 6800





PIEDE DI ACCOPPIAMENTO
AUTOMATIC COUPLING FOOT



 Pompe sommergibili adatte alla movimentazione di acque sporche e rifiuti industriali contenenti corpi solidi o filamentosi, fognature urbane e liquami di stalla. Motore 4 poli. Robusta costruzione. Coperchio, cassa statore e corpo mandata in ghisa. Girante monocanale in ghisa. Albero in acciaio inox AISI 420. Doppia tenuta meccanica in camera d'olio: entrambe le tenute sono in carburo di silicio. Cavo di alimentazione di 10 metri in neoprene H07RN8-F tensione trifase 400/690V. Protezione a cura dell'utente. Protezione IP 68. Isolamento classe F. Temperatura massima del liquido da pompare 40 °C; pH: 6 – 10; massima densità 1100 kg/m³.

 Submersible pumps suitable for the pumping of sewage effluents containing solid or fibrous parts in industrial, agricultural and domestic waste water plants. 4 poles motor. Heavy duty construction. Pump housing and impeller in cast-iron. Single channel impeller. Shaft in stainless steel AISI 420. Double mechanical seal in oil chamber: both the mechanical seals are in silicon carbide. 10 metres supply cable H07RN8-F three-phase voltage 400/690V. The pumps must be protected by a fused remote isolator switch. Protection class IP 68. Insulation class F. Max. temperature of pumped liquid 104 °F (40 °C); pH: 6 – 10; max. density 1100 kg/m³.

 Pompes submersibles indiquées pour eaux chargées avec corps solides ou fibreux. Particulièrement conseillées pour eaux résiduaires, pour traitement des eaux industrielles et pour d'autres emplois dans le domaine agricole et zootechnique. Moteur 4 pôles. Construction robuste. Couvercle, corps de pompe et corps de refoulement en fonte. Roue monocanal en fonte. Arbre en acier inox AISI 420. Double garniture mécanique en chambre d'huile: toutes les deux garnitures mécaniques sont en carbure de silicium. Câble électrique H07RN8-F de 10 mètres bobinage triphasé 400/690V. Protection par l'utilisateur. Protection IP 68. Isolation classe F. Température max. du liquide pompé: 40 °C; pH: 6 – 10; densité max. 1100 kg/m³.

 Abwasser-Tauchpumpen für Schmutzwasser mit Festkörper und Faserstoffen. Diese Pumpen sind aus hochwertigen Materialien hergestellt. 4 Pol Motor. Pumpengehäuse und Laufrad aus Grauguß. Einkanallaufgrad. Antriebswelle aus rostfreiem Stahl AISI 420. Ölgekühlte Doppel-Gleitringdichtung: aus Siliziumkarbid. 10 Meter Kabel H07RN8-F Dreiphasenspannung 400/690V. Motorvollschutz nach Benutzersorge. IP 68 Schutz. Isol. Klasse F. Max. Temperatur der Flüssigkeit: 40 °C; pH: 6 – 10; max. Dichte: 1100 kg/m³.

Modello Model Modèle Modell	Potenza Power Puissance Pferdestärke		Tensione Voltage Bobinage Spannung V-Hz-ph	A	Prevalenza - Head - Hauteur - Förderhöhe (m)						
	HP	kW			4	8	12	16	24	32	40
					Portata - Capacity - Débit - Fördermenge (l/min)						
VORTEX 1000	10	7,5	400/690-50-3	15,6/10,0	4500	3320	2150	900			
VORTEX 1500	15	11	400/690-50-3	23,4/14,0	5500	4070	2750	1425			
VORTEX 2000	20	15	400/690-50-3	31,8/18,5	6000	4700	3300	2000			
VORTEX 2700	27	20	400/690-50-3	39,7/22,9	7000	6000	4870	3720	1130		
VORTEX 3400	34	25	400/690-50-3	47,7/27,6	7200		6010	4950	2630		
VORTEX 4000	40	35	400/690-50-3	59,0/34,1	8500		7500	6350	4200	1900	
VORTEX 5500	55	40	400/690-50-3	73,1/42,2	8700		7750	5750	3750	1730	
VORTEX 6800	68	51	400/690-50-3	98,6/56,9	7700		5630	3380			

*On request other voltages are available

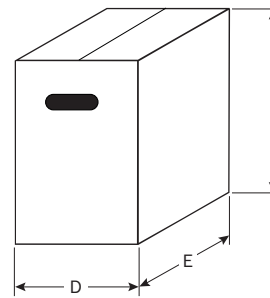
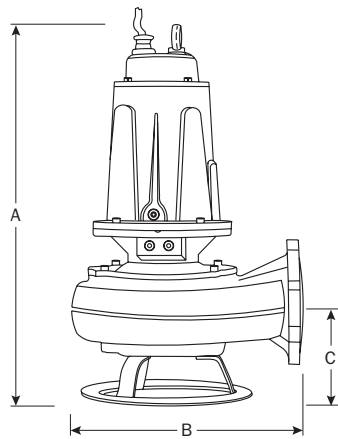
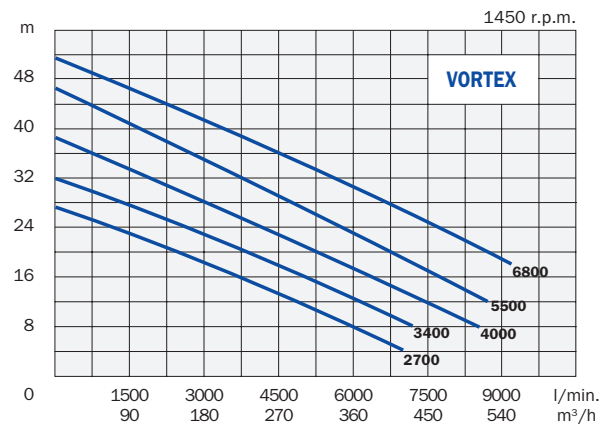
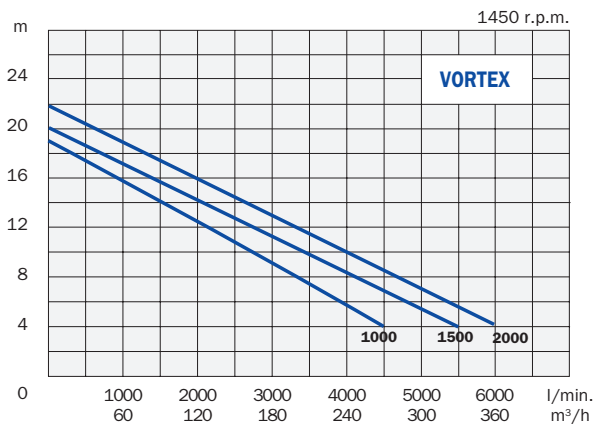

Modello Model Modèle Modell	Mandata Discharge Refoulement Druck-Seite	Corpi solidi Solid parts Corps solides Festkörper	Dimensioni - Dimensions - Masstabelle						Peso Weight Poids Gewicht
			mm						
			A	B	C	D	E	F	
VORTEX 1000	6" - DN 150 horizontal	100	720	528	267	540	430	640	122
VORTEX 1500	6" - DN 150 horizontal	110	956	641	325	670	570	950	260
VORTEX 2000	6" - DN 150 horizontal	110	956	641	325	670	570	950	272
VORTEX 2700	6" - DN 150 horizontal	120	997	641	325	670	570	950	308
VORTEX 3400	6" - DN 150 horizontal	120	997	641	325	670	570	950	320
VORTEX 4000	6" - DN 150 horizontal	120	1190	850	345	980	730	1310	550
VORTEX 5500	6" - DN 150 horizontal	120	1190	850	345	980	730	1310	585
VORTEX 6800	6" - DN 150 horizontal	130	1190	850	345	980	730	1310	600

NEW

POMPE TRITURATRICI GRINDER PUMPS



GRINDER / 23

 Modelli altamente professionali ed affidabili indicati per servizi igienici pubblici, alberghi, campeggi, ristoranti, ospedali, ecc. e che sono in grado di tritare facilmente pannolini, tovaglioli, pezzi di stoffa, cordicelle, oggetti di plastica, gomma, lattice, ecc. Robusta struttura in ghisa. Doppia tenuta meccanica in carburo di silicio in camera d'olio. Dispositivo trituratore in acciaio inox temperato. Cavo di alimentazione di 10 metri in neoprene H07RNF. I modelli monofase sono dotati di un quadretto elettrico all'estremità del cavo con una termica a riarmo manuale ed un condensatore aggiuntivo per aumentare lo spunto. Isolamento classe F. Protezione IP68. Temperatura massima del liquido da pompare: 40 °C; pH: 6 - 10; massima densità del liquido: 1100 Kg/m³.

 These models are very professional and reliable. Suitable for hotels, restaurants, camping, hospitals, etc. They can easily chop up sanitary towels, napkins, little ropes, objects in plastic, rubber, latex, etc. Heavy duty structure in cast iron. Double mechanical seal in silicon carbide in oil chamber. Cutting system in tempered stainless steel. 10 meters supply cable H07RNF. The single-phase models are equipped with a control box at the end of the cable with a manual reset protection and an additional capacitor to increase the starting torque. Insulation class F. Protection IP68. Max. temperature of pumped liquid: 104 °F (40 °C); pH: 6 - 10; max. density: 1100 Kg/m³.

 Pompes de haute qualité pour hôtels, restaurants, hôpitaux, etc. Elles peuvent triturer serviettes hygiéniques, ficelles, objets en plastique, en gomme, en latex, etc. Construction robuste en fonte. Double garniture mécanique en carbure de silicium en chambre d'huile. Broyeur en acier inox trempé. Câble électrique H07RNF de 10 mètres. Les modèles monophasés sont équipés d'un boîtier de commande en extrémité de câble avec une protection à réarmement manuel et d'un condensateur supplémentaire pour augmenter le couple de démarrage. Isolation classe F. Protection IP 68. Température max. du liquide pompé: 40 °C; pH: 6 - 10; densité max. 1100 kg/m³.

 Diese Modelle sind ausgesprochen professionell und zuverlässig. Geeignet für den Einsatz in der öffentlichen Hygiene, in Hotels, auf Campingplätzen, in Restaurants, Krankenhäusern usw. Sie sind in der Lage, ohne Probleme Windeln, Servietten, Stoffstücke, Kordeln, Gegenstände aus Gummi, Kunststoff, Latex usw. zu zerhacken. Robuste Struktur aus Grauguss. Ölgekühlte Doppel-Gleitringdichtung aus Siliziumkarbid. Hack Werk aus rostfreiem Stahl. 10 Meter Kabel H07RNF. Die einphasigen Modelle sind am Ende des Kabels mit einer Steuerbox mit manuellem Rückstellschutz und einem zusätzlichen Kondensator zur Erhöhung des Anlaufdrehmoments ausgestattet. Isol. Klasse F. IP 68 Schutz. Max. Temperatur der Flüssigkeit: 40 °C; pH: 6 - 10; Max. Dichte 1100 kg/m³.

Modello Model	Potenza Power		Tensione Voltage	I _n A	Prevalenza - Head (m)								
	HP	kW			2	4	8	12	16	20	24	28	
	Portata - Capacity (l/min)												
GRINDER 100	1.0	0.75	230/50/1	6,1	168	159	130	88	30				
GRINDER 200	2.0	1.5	230/50/1	12,50	170	169	167	156	130	88			
			400/50/3	4,0									
GRINDER 300	3.0	2.2	400/50/3	5,3	175	173	173	171	166	130	116	60	
GRINDER 500	5.0	3.7	400/50/3	8,2			320	295	260	219	163	100	

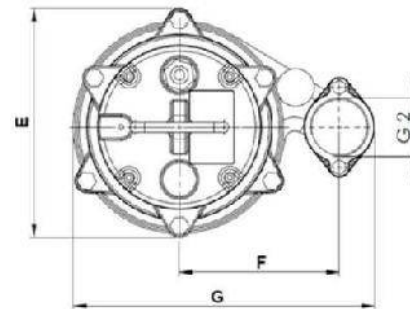
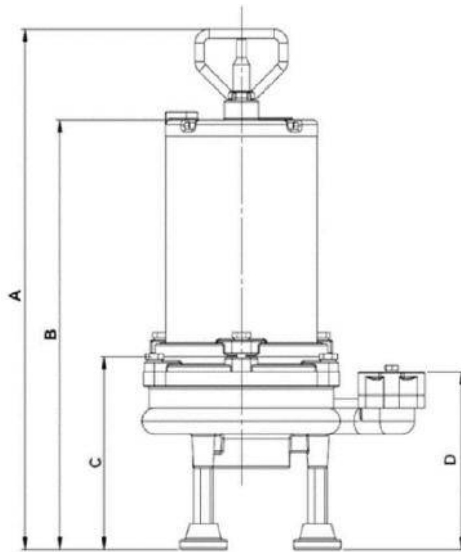
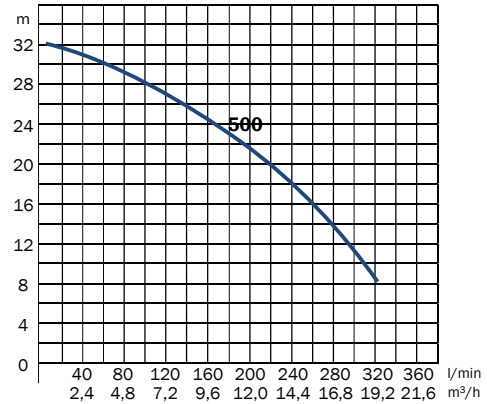
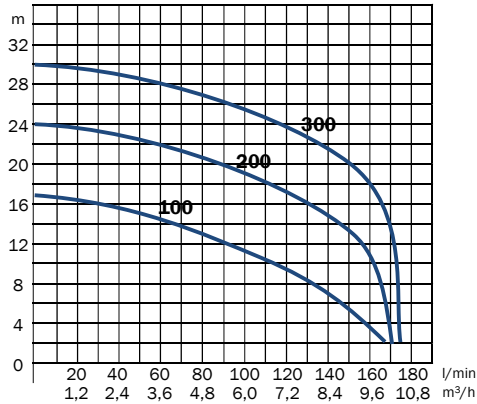

Modello Model	Mandata Discharge	Dimensioni / Dimensions mm							Peso Weight kg
		A	B	C	D	E	F	G	
GRINDER 100 M	2" vertical	460	397	174	155	220	165	290	27
GRINDER 200 M	2" - DN50 vertical	637	539	209	192	237	163	307	44
GRINDER 200 T	2" - DN50 vertical	563	465	209	192	233	163	307	42
GRINDER 300 T	2" - DN50 vertical	563	465	209	192	233	163	307	43
GRINDER 500 T	2" - DN50 vertical	626	541	209	234	226	205	395	53

POMPE SOMMERGIBILI AISI 304

SUBMERSIBLE PUMPS AISI 304

VORTEX SS 304



DRAIN SS 304



 Le **VORTEX SS 304** sono pompe sommergibili con girante arretrata di tipo “vortex” adatte per fosse biologiche, per scarichi di lavatrici, di lavastoviglie, ecc.

Le **DRAIN SS 304** sono pompe sommergibili con girante multicanale per il drenaggio di acque piovane o leggermente sabbiose.

Cassa statore, corpo pompa e girante in acciaio inossidabile AISI 304. Doppia tenuta meccanica in carburo di silicio a bagno d’olio. Albero motore in acciaio inox. Tensione monofase con condensatore e protezione termica incorporati; tensione trifase con protezione a cura dell’utente. Cavo di alimentazione di 10 metri. Protezione IP 68. Isolamento classe F. Temperatura massima dell’acqua: 40 °C; pH: 6 – 13; massima densità 1000 kg/m³.

 **VORTEX SS 304** are submersible pumps with back open impeller “vortex” type suitable for the pumping of sewage water with solid parts.

DRAIN SS 304 are submersible pumps with multichannel impeller suitable to remove clean water or slightly sandy water. Motor case, pump body and impeller in stainless steel AISI 304. Double mechanical seal in silicon carbide in oil chamber. Motor shaft in stainless steel. Single-phase voltage with built-in capacitor and motor protector. The three-phase pump must be protected by a fused remote isolator switch. 10 metres supply cable. Protection class IP 68. Insulation class F. Max water temperature: 104 °F (40 °C); pH: 6 – 13; max. density 1000 kg/m³.

 **VORTEX SS 304** sont des pompes submersibles avec roue “vortex” pour eaux chargées, vide-caves, etc.

DRAIN SS 304 sont des pompes submersibles avec roue multicanal pour le drainage d’eau météorique ou d’eau en peu sablonneuse.

Coquille-stator, corps de pompe et roue en acier inox AISI 304. Double garniture mécanique en carbure de silicium à bain d’huile. Arbre moteur en acier inox. Bobinage monophasé avec condensateur et protection thermique incorporés; bobinage triphasé avec protection par l’usager. Câble électrique de 10 mètres. Protection IP 68. Isolation classe F. Température max de l’eau: 40 °C; pH: 6 – 13; densité max 1000 kg/m³.

 **VORTEX SS 304:** Tauchpumpen mit “Vortex” Laufrad für Sickergruben, für Abflüsse von Waschmaschinen, Geschirrspülmaschinen usw.

DRAIN SS 304: Tauchpumpen mit Multikanallaudfrad zum Abpumpen von Regenwasser oder Wasser mit geringem Sandgehalt.

Statorgehäuse, Pumpengehäuse und Laufrad aus rostfreiem Stahl AISI 304. Ölgekühlte Doppel-Gleitringdichtung aus Siliziumkarbid. Antriebswelle aus rostfreiem Stahl. 10 Meter Kabel H07RNF. Einphasenspannung mit Kondensator und thermischen Motorschutz; Dreiphasenspannung, Motorvollschutz nach Benutzersorge. Isol. Klasse F. IP 68 Schutz. Max Temperatur der Flüssigkeit: 40 °C; pH: 6 – 13; Max Dichte: 1000 kg/m³.

Modello Model Modèle Modell	Potenza Power Puissance Pferdestärke		Tensione Voltage Bobinage Spannung	A	Prevalenza - Head - Hauteur - Förderhöhe (m)								
	HP	kW			Portata - Capacity - Débit - Fördermenge (l/min)								
					0	2	4	6	8	10	12		
VORTEX 75 SS 304	0,75	0,55	230-50-1	4,2	245	220	170	103	20				
VORTEX 100 SS 304	1	0,75	230-50-1	5,9	285	265	218	160	90	6			
VORTEX 150 SS 304	1,5	1,1	230-50-1	7,0	400	380	338	280	205	127	36		
			400-50-3	2,5									
VORTEX 200 SS 304	2	1,5	230-50-1	9,5	505	502	468	393	300	209	105		
			400-50-3	3,5									
DRAIN 75 SS 304	0,75	0,55	230-50-1	3,2	225	203	166	128	82	31			
DRAIN 100 SS 304	1	0,75	230-50-1	5,9	360	331	285	230	165	92	10		
DRAIN 150 SS 304	1,5	1,1	230-50-1	7,0	450	440	373	300	223	140	52		
			400-50-3	2,5									

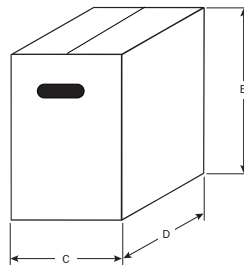
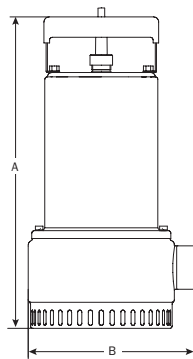
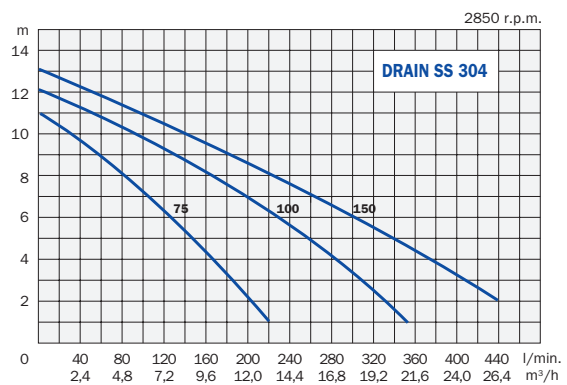
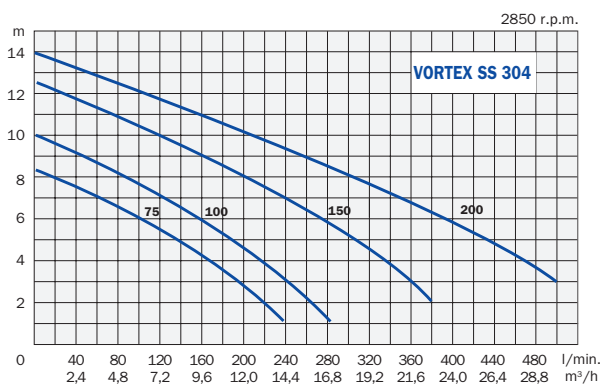



Modello Model Modèle Modell	Mandata Discharge Refoulement Druck-Seite	Corpi solidi Solid parts Corps solides Festkörper	Dimensioni - Dimensions - Masstabelle					Peso Weight Poids Gewicht
			mm					
			A	B	C	D	E	
VORTEX 75 SS 304	1"1/2 - DN 40 horizontal	38	370	195	230	200	470	13
VORTEX 100 SS 304	1"1/2 - DN 40 horizontal	38	400	195	230	200	470	14
	2" - DN 50 horizontal			205				
VORTEX 150 SS 304	2" - DN 50 horizontal	38	400	205	230	200	470	15
VORTEX 200 SS 304	2" - DN 50 horizontal	45	465	210	295	255	490	19
DRAIN 75 SS 304	1"1/2 - DN 40 horizontal	5	360	195	230	200	470	12
DRAIN 100 SS 304	1"1/2 - DN 40 horizontal	5	390	195	230	200	470	14
DRAIN 150 SS 304	2" - DN 50 horizontal	5	390	210	230	200	470	15





POMPE SOMMERGIBILI PER LIQUIDI CORROSIVI CORROSION RESISTANT SUBMERSIBLE PUMPS



 Pompe particolarmente indicate per fognature aggressive, industria chimica, farmaceutica, alimentare, galvanica, tessile, conciaria, lavorazione dei metalli, ecc. Robusta costruzione. Cassa statore, corpo pompa e girante in acciaio inossidabile AISI 316. Girante arretrata tipo "vortex" sui modelli da 1 e 1.4 HP; girante aperta di tipo bicanale sui modelli da 2 a 10 HP. Doppia tenuta meccanica in carburo di silicio a bagno d'olio. Guarnizioni in Viton. Cavo di alimentazione di 10 metri in neoprene H07RNF. Protezione IP 68. Isolamento classe F. Temperatura massima dell'acqua: 40 °C, pH: 3 - 14, massima densità 1100 kg/m³.

 These pumps are particularly recommended for aggressive sewage effluents, for acid and alkaline solutions in the pharmaceutical, chemical, galvanic, textile, tanning, metal processing and food industries. Heavy duty construction. Motor case, pump body and impeller are in stainless steel AISI 316. Back open impeller "vortex" type on models 0.75 and 1.04 kW; open type double-channel impeller on models from 1.5 to 7.5 kW. Silicon carbide double mechanical seal in oil chamber. Viton packing. 10 meters cable H07RNF. Protection class IP 68. Insulation class F. Max water temperature: 104 °F (40 °C), pH: 3 - 14, max. density 1100 kg/m³.

 Pompes submersibles indiquées pour eaux chargées particulièrement corrosives des industries chimiques, pharmaceutiques, alimentaires, galvaniques, textiles, tanneries, métallurgiques, etc. Construction robuste. Coquille stator, corps de pompe et roue en acier inox AISI 316. Roue "vortex" sur les modèles de 1 et 1.4 CV; roue de type bi canal ouvert sur les modèles de 2 jusqu'à 10 CV. Double garniture mécanique en carbure de silicium en chambre d'huile. Garnitures en Viton. Câble électrique de 10 mètres. Protection IP 68. Isolation class F. Température max. de l'eau: 40 °C, pH: 3 - 14, densité max 1100 kg/m³.

 Pumpen, die besonders für aggressive Abwässer, die chemische und die pharmazeutische Industrie, die Lebensmittelindustrie, Galvanisierungsbetriebe, die Textilindustrie, Gerbereien, Metall verarbeiteten Unternehmen usw. geeignet sind. Hergestellt aus hochwertigen und widerstandsfähigen Materialien. Statorgehäuse, Pumpengehäuse und Laufrad aus rostfreiem Stahl AISI 316. Wirbellaufgrad bei den Modellen mit 0.75 und 1.04 kW; Zweikanallaufgrad auf Modellen mit 2 bis zu 10 HP. Ölgekühlte Doppel-Gleitringdichtung aus Siliziumkarbid. Viton-Dichtungen. 10 Meter Kabel H07RNF. IP 68 Schutz. Isol. klasse F. Max. Temperatur der Flüssigkeit: 40 °C, pH: 3 - 14, Max Dichte: 1100 kg/m³

Modello Model	Potenza Power		Tensione Voltage	I _n A	Prevalenza - Head (m)							
					2	4	8	12	16	20	24	28
	HP	kW			Portata - Capacity (l/min)							
VORTEX 100 SS 316 / VX1	1.0	0.75	230/50/1	6,6	380	322	175					
			400/50/3	2,8								
VORTEX 140 SS 316 / VX1	1.4	1.04	230/50/1	7,2	460	400	255	90				
			400/50/3	3,0								
VORTEX 200 SS 316 / 23	2.0	1.5	400/50/3	3,9	900	765	500	205				
VORTEX 300 SS 316 / 23	3.0	2.2	400/50/3	5,1	1120	1042	865	655	380			
VORTEX 500 SS 316 / 23	5.0	3.7	400/50/3	8,4	1240	1080	890	645	340			
VORTEX 750 SS 316 / 23	7.5	5.5	400/50/3	11,3	1425	1325	1200	1115	865	490		
VORTEX 1000 SS 316 / 23	10	7.5	400/50/3	16,5	2400	2250	1945	1635	1260	840	590	210

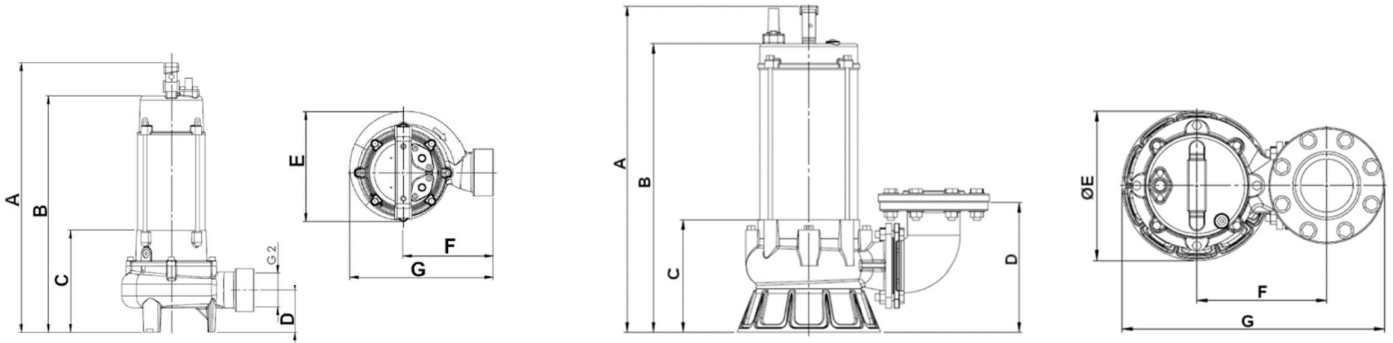
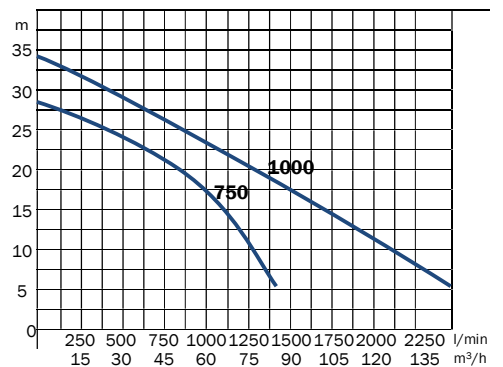
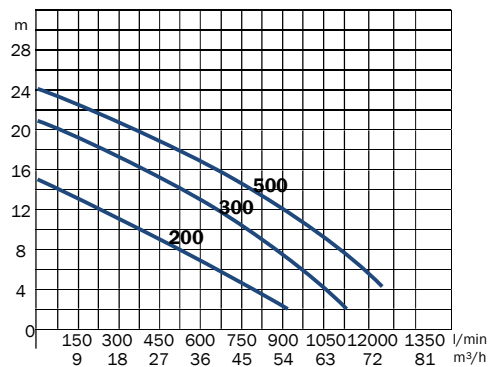
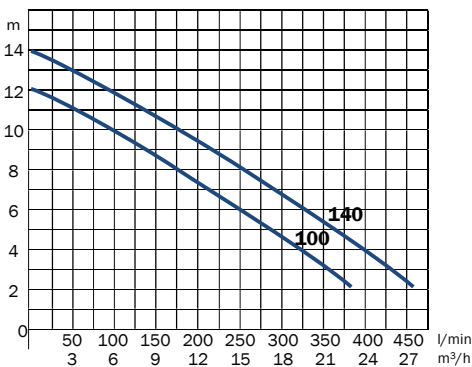

Modello Model	Mandata Discharge	Corpi solidi Solid parts	Dimensioni Dimensions mm							Peso Weight
			mm	A	B	C	D	E	F	
VORTEX 100 SS 316 / VX1	2" - DN50 horizontal	45	453	398	171	71	171	223	139	16,5
VORTEX 140 SS 316 / VX1	2" - DN50 horizontal	45	453	398	171	71	171	223	139	17
VORTEX 200 SS 316 / 23	3" - DN80 vertical	35	493	421	166	190	227	208	374	33
VORTEX 300 SS 316 / 23	3" - DN80 vertical	35	543	480	186	215	240	209	422	43
VORTEX 500 SS 316 / 23	3" - DN80 vertical	35	612	512	187	215	240	209	422	47
VORTEX 750 SS 316 / 23	4" - DN100 vertical	35	619	519	196	247	238	260	484	60
VORTEX 1000 SS 316 / 23	4" - DN100 vertical	35	698	617	244	300	298	305	556	91

STAZIONI DI POMPAGGIO “ECOBX” PER ACQUE NERE

PUMPING STATIONS “ECOBX” FOR SEWAGE WATER



ECOBX 175 L



ECOBX 550 L



ECOBX 1000 L - 1500 L



Le stazioni di pompaggio “ECOBX” in polietilene vengono utilizzate per la raccolta ed il sollevamento di acque nere in conformità alle vigenti disposizioni di legge che tutelano le falde sotterranee dall’inquinamento. La chiusura ermetica garantisce igiene ed assenza di odori. Possono essere installate in taverne, scantinati, garage oppure interrato. Le vasche sono già fornite della tubazione di mandata, dei raccordi di entrata e di ventilazione e del piede di accoppiamento rapido per il posizionamento della pompa. Le vasche sono inoltre dotate di maniglie per facilitarne lo spostamento e l’installazione. La vasca **ECOBX 175 L** viene generalmente utilizzata in abitazioni singole ed è predisposta per una sola pompa sommersibile.

Le vasche **ECOBX 550 L, 1000 L e 1500 L** sono idonee all’utilizzo in condomini, alberghi, ristoranti, ecc. e possono essere predisposte per una o due pompe sommersibili. È disponibile anche un quadro elettrico per il funzionamento alternato delle due pompe. Le vasche ECOBOX possono essere impiegate anche per la raccolta e il riutilizzo delle acque piovane.

Su richiesta sono disponibili vasche più capienti.

ECOBX pumping stations in polyethylene are used to collect and pump out sewage waters in conformity with the effective laws protecting underground water layers from pollution. The hermetic enclosure grants hygiene and absence of smell. The tanks can be installed in cellars, garages or interred. They are supplied with discharge tube, inlet and ventilation connections and coupling foot for the pump. Moreover the tanks are supplied with handles to make the handling and the installation easier.

Tank **ECOBX 175 L** is usually used in single houses and it is arranged for only one submersible pump.

Tanks **ECOBX 550 L, 1000 L and 1500 L** are used in blocks of flats, hotels, restaurants, etc. and they can be arranged for one or two submersible pumps. It is available also a switch board for the alternate working of the pumps.

Tanks ECOBOX can be used also for the collection and reuse of the rain water.

On request larger tanks are available.

Stations de relevage ECOBOX pour eaux chargées. Solution idéale quand les eaux ménagères doivent être pompées aux réseaux d’égout car l’écoulement par gravité n’est pas possible. Les stations ECOBOX peuvent être placées dans la cave, dans le garage; elles peuvent être aussi enterrées. Elles sont fournies avec raccords d’entrée, de refoulement et de ventilation, ainsi que avec pied pour l’accouplement rapide de la pompe. En outre les stations sont fournies des poignées pour un déplacement et une installation plus faciles.

Dans la station **ECOBX 175 L** est installée une seule pompe submersible.

Dans les stations **ECOBX 550 L, 1000 L et 1500 L** peuvent être installées une ou deux pompes submersibles.

Est disponible aussi un tableau électrique pour le fonctionnement alterné de deux pompes.

Les stations ECOBOX peuvent être employées pour l’utilisation des eaux pluviales.

Cuves plus grands sont disponibles à la demande.

Die Behälter "ECOBIX" aus Polyethylen werden zum Auffangen und Heben der Abwässer entsprechend den gültigen gesetzlichen Bestimmungen, die das Grundwasser vor der Verschmutzung schützen, verwendet. Der hermetische Verschluss und der Ventilationsschlauch versichern die Hygiene und Geruchlosigkeit. Sie können in Tavernen, Kellerräumen, Garagen oder unterirdisch verlegt werden. Die Behälter werden bereit mit dem Förderschlauch, den Eingangs- und Ventilationsverbindungsstücken sowie den Füßen für den Schnellanschluss zum Aufstellen der Pumpe geliefert. Die Behälter haben auch Handgriffe für einen leichten Transport und Verlegung.

Der Behälter **ECOBIX 175 L** ist für die Verwendung in Privatwohnungen gedacht und für eine einzige Pumpe.

Der Behälter **ECOBIX 550 L, 1000 L** und **1500 L** ist für die Verwendung in Wohnhäusern, Hotels, Restaurants usw. geeignet und für eine oder zwei Pumpen eingerichtet. Lieferbar ist ein Schaltfeld für den abwechselnden Betrieb der beiden Pumpen erhältlich.

Die Behälter "ECOBIX" können auch für den Rückhalt und die Wiederverwendung des Regenwassers verwendet werden.

Auf Wunsch sind größere Behälter lieferbar.

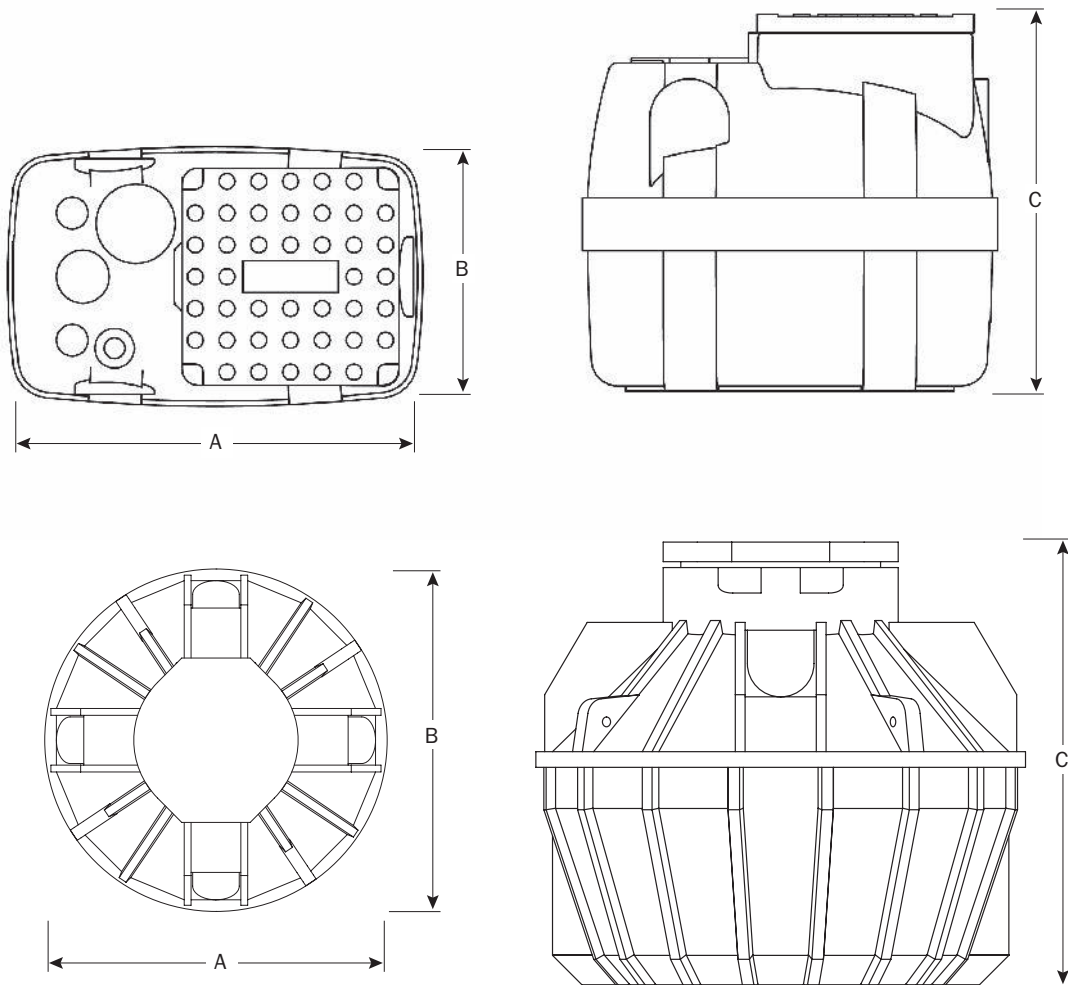

Modello Model Modèle Modell	Capacità Capacity Capacité Kapazität litres	Dimensioni - Dimensions - Masstabelle mm			Peso senza pompa Weight without pump Poids sans pompe Gewicht ohne Pumpe kg
		A	B	C	
ECOBIX 175 L	175	785	490	713	22
ECOBIX 550 L	550	923	1135	871	52
ECOBIX 1000 L	1000	1250	1250	1130	65
ECOBIX 1500 L	1500	1250	1250	1730	92

POMPE PER DRENAGGIO

DRAINAGE PUMPS

SAND 100





SAND 150-200





SAND 300



 Pompe sommergibili particolarmente indicate per acque sabbiose, scavi edilizi, impianti di verniciatura, scantinati. Robusta costruzione. Coperchio, cassa statore, corpo di mandata e supporto in ghisa. Girante in ghisa di tipo bicanale aperto. Albero in acciaio inox temperato e rettificato. Motore a bagno d'olio. Tenuta meccanica in carburo di silicio ed anello di tenuta sui modelli SAND 50 e SAND 100. Doppia tenuta meccanica in carburo di silicio sui modelli SAND 150, SAND 200 e SAND 300. Cavo di alimentazione di 10 metri in neoprene H07RNF sul modello SAND 50, in H07RN8-F su tutti gli altri modelli. Tensione monofase con condensatore e protezione termica incorporati; tensione trifase con protezione a cura dell'utente. Protezione IP 68. Isolamento classe F. Temperatura massima del liquido da pompare 40 °C; pH: 6 – 10; massima densità < 1100 kg/m³.

 Submersible pumps suitable to remove sandy water, drainage of foundation trenches, subways, varnishing plants, etc. Heavy duty construction. Pump housing in cast iron. Open-type double channel impeller in cast iron. Oil bathed motor. Shaft in stainless steel. Mechanical seal in silicon carbide and lip seal ring on the models SAND 50 and SAND 100. Double mechanical seal in silicon carbide in oil chamber on the models SAND 150, SAND 200 and SAND 300. 10 metres supply cable H07RNF on model SAND 50, cable H07RN8-F on all other models. Single-phase voltage with built-in capacitor and motor protector; the three-phase voltage pump must be protected by a fused remote isolator switch. Protection class IP 68. Insulation class F. Max. temperature of pumped liquid 104 °F (40 °C); pH: 6 – 10; max. density < 1100 kg/m³.

 Pompes submersibles indiquées pour le drainage des eaux contenant du sable, fouilles de fondations, vide-caves, passages souterrains, cabines de peinture, etc. Construction robuste. Couvercle, corps de pompe, corps de refoulement et support en fonte. Roue en fonte de type bicanal ouvert. Arbre en acier inox. Moteur à bain d'huile. Garniture mécanique en carbure de silicium et bague d'étanchéité à lèvres sur les modèles SAND 50 et SAND 100. Double garniture mécanique en chambre d'huile en carbure de silicium sur les modèles SAND 150, SAND 200 et SAND 300. Câble électrique H07RNF de 10 mètres sur le modèle SAND 50, câble H07RN8-F sur tous les autres modèles. Bobinage monophasé avec condensateur et protection thermique incorporés; bobinage triphasé avec protection par l'utilisateur. Protection IP 68. Isolation classe F. Température max. du liquide pompé 40 °C; pH: 6 – 10; densité max. < 1100 kg/m³.

 Tauchpumpen für Regen- und Sandwasser. Hergestellt aus hochwertigen und widerstandsfähigen Materialien. Pumpengehäuse und Zweikanallauftrieb aus Grauguß. Antriebswelle aus rostfreiem Stahl. Ölgefüllter Tauchmotor. Gleitringdichtung aus Siliziumkarbid und Öldichtungsring bei Modellen SAND 50 und SAND 100. Ölgekühlte Doppelgleitringdichtung aus Siliziumkarbid bei Pumpen SAND 150, SAND 200 und SAND 300. 10 Meter Kabel H07RNF beim Modell SAND 50, 10 Meter Kabel H07RN8-F beim Modellen SAND 100, SAND 150, SAND 200 und SAND 300. Einphasenspannung mit Kondensator und thermischen Motorschutz; Dreiphasenspannung: Motorvollschutz nach Benutzersorge. IP 68 Schutz. Isol. Klasse F. Max. Temperatur der Flüssigkeit 40 °C; pH: 6 – 10; max. Dichte < 1100 kg/m³.

Modello Model Modèle Modell	Potenza Power Puissance Pferdestärke		Tensione Voltage Bobinage Spannung V-Hz-ph	A	Prevalenza - Head - Hauteur - Förderhöhe (m)															
	HP	kW			Portata - Capacity - Débit - Fördermenge (l/min)															
					2	4	6	8	10	12	14	16	18	20						
SAND 50	0,5	0,37	230-50-1	3,0	200	166	117	50												
SAND 100	1	0,75	230-50-1	5,0	315	270	220	170	100	40										
			400-50-3	2,4																
SAND 150	1,5	1,1	230-50-1	8,5	400	350	300	250	200	125	50									
			400-50-3	3,5																
SAND 200	2	1,5	230-50-1	10,9	545	500	445	390	325	255	180	100								
			400-50-3	4,6																
SAND 300	3	2,2	400-50-3	5,4	670	625	570	510	450	380	310	230	140	50						

*On request other voltages are available

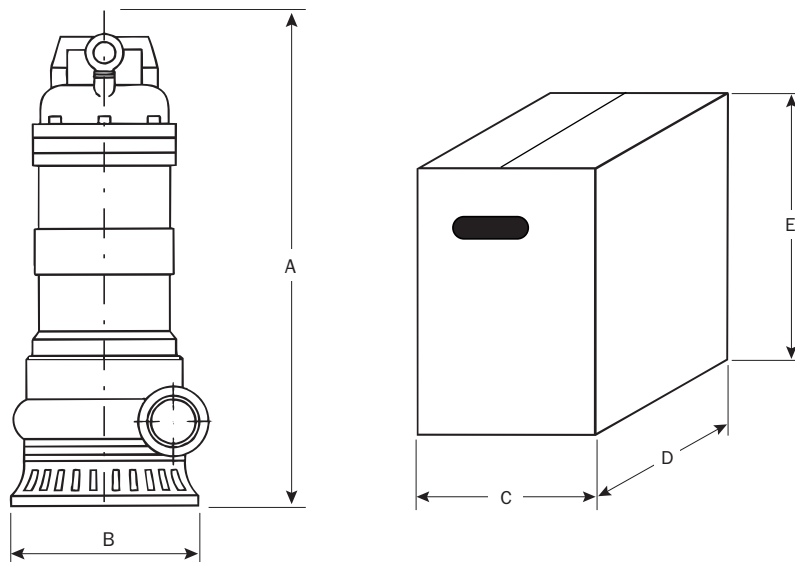
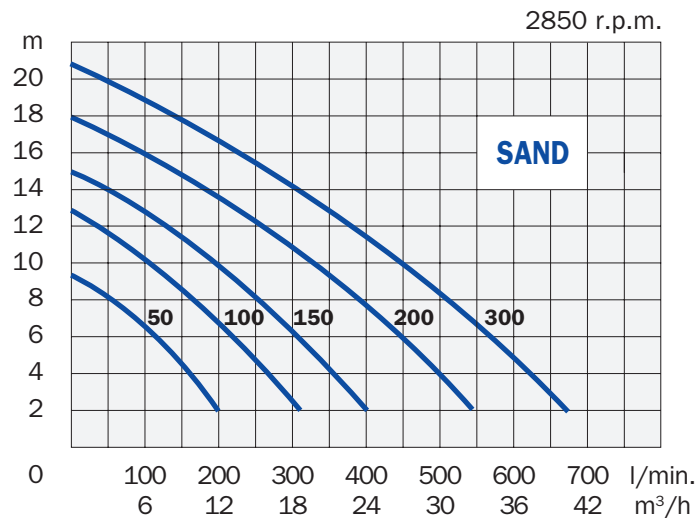

Modello Model Modèle Modell	Mandata Discharge Refoulement Druck-Seite	Corpi solidi Solid parts Corps solides Festkörper	Dimensioni - Dimensions - Masstabelle					Peso Weight Poids Gewicht
			mm					
			A	B	C	D	E	
SAND 50	1"1/4 - DN 32 horizontal	4	315	140	230	195	420	12
SAND 100	1"1/2 - DN 40 horizontal	5	410	165	230	200	470	23
SAND 150	2" - DN 50 horizontal	8	514	200	295	255	550	36
SAND 200	2" - DN 50 horizontal	8	514	200	295	255	550	37
SAND 300	3" - DN 80 horizontal	8	525	210	295	255	550	41



POMPE PER CANTIERISTICA CONTRACTOR PUMPS



SUPERSAND N / 23

 Pompe sommergibili progettate per pompare acque fangose e sabbiose. Vengono usate nell'ingegneria civile per il drenaggio di fondamenta, di sottopassi, di gallerie, ecc. L'intercapedine tra la cassa motore e il corpo pompa assicura il raffreddamento del motore anche quando il livello dell'acqua da pompare è molto basso. I modelli a partire da 3HP sono dotati di agitatore. Carcasa esterna in acciaio inossidabile AISI 304. Girante multicanale in ghisa temperata con alta percentuale di cromo, resistente all'abrasione: durezza RC 60. Doppia tenuta meccanica in carburo di silicio in camera d'olio. Cavo di alimentazione di 20 metri in neoprene Ho7RNF. Protezione termica e amperometrica a riarmo automatico. Protezione IP 68. Isolamento classe F. Immersione massima della pompa: 30 metri. Temperatura massima del liquido da pompare: 40 °C; pH: 6 - 13; massima densità del liquido: 1100 Kg/m³.

 Submersible pumps for muddy and sandy water. These pumps have been proved to be suitable in civil engineering: digging out works, dewatering of tunnels, draining-off flooded basements, etc. The flow of water through a double pump casing avoids motor over-heating, therefore the pump can run also with a low water level. Models starting from 2.2kW are equipped with an agitator. Pump housing in stainless steel AISI 304. Multichannel impeller abrasion resistant in cast-iron and chrome with a hardness of RC 60. Double silicon carbide mechanical seal in oil chamber. 20 meters supply cable Ho7RNF. Automatic reset motor protector. Protection class IP 68. Insulation class F. Max submersion of pump: 30 meters. Temperature of pumped liquid: max 104 °F (40 °C); pH: 6 - 13; max. density: 1100 Kg/m³.

FR Pompes submersibles conçues pour pomper des eaux boueuses et sableuses: elles trouvent emploi pour le drainage de fouilles de fondation, de caves, de passages souterrains, etc. Le vide entre la carcasse extérieure et celle du stator permet le refroidissement du moteur même si le niveau de l'eau à pomper est très bas. Les modèles à partir de 3CV sont équipés d'un agitateur. La carcasse extérieure est en acier inox AISI 304. La roue multicanal est en fonte au chrome trempé résistant à l'abrasion: dureté 60 RC. Double garniture mécanique en carbure de silicium à bain d'huile. Câble électrique Ho7RNF de 20 mètres. Protection thermique incorporée. Protection IP 68. Isolation classe F. Profondeur d'installation de la pompe: max. 30 mètres. Température max. du liquide pompé: 40 °C; pH: 6 – 13; densité max. 1100 kg/m³.

DE Tauchpumpen zum Pumpen von schlammigem und sandigem Wasser. Werden im Bausektor zum Auspumpen von Fundamenten, Unterführungen, Stollen usw. eingesetzt. Der Zwischenraum zwischen dem Motorgehäuse und dem Pumpengehäuse gewährleistet die Kühlung des Motors, auch wenn der Pegel des zu pumpenden Wassers sehr niedrig ist. Modellen ab 2,2 kW sind mit einem Rührwerk ausgestattet.

Pumpengehäuse aus rostfreiem Stahl AISI 304. Das mehrkanalige Laufrad besteht aus gehärtetem abriebbeständigem Grauguss mit Chrom: Härte 60 RC. Ölgekühlte Doppel-Gleitringdichtung aus Siliziumkarbid. 20 Meter Kabel Ho7RNF. Thermo und Ampereschutzschalter. IP 68 Schutz. Isol. Klasse F. Max. Tauchtiefe der Pumpe: 30 Meter. Max. Temperatur der Flüssigkeit: 40 °C; pH: 6 - 13; Max. Dichte 1100 kg/m³.

Modello Model	Potenza Power		Tensione Voltage	Poles	I _n A	Prevalenza - Head (m)							
	HP	kW				2	5	10	15	20	25	30	35
SUPERSAND N 150 / 23	1.5	1.1	230/50/1	2	9,0	475	405	220					
SUPERSAND N 300 / 23	3.0	2.2	400/50/3	2	5,1	800	682	425	150				
SUPERSAND N 500 / 23	5.0	3.7	400/50/3	2	7,6	1300	1125	745	360				
SUPERSAND N 750 / 23	7.5	5.5	400/50/3	2	13,3	1400	1350	1170	950	700	390		
SUPERSAND N 1000 / 23	10	7.5	400/50/3	2	15,3	1500	1450	1300	1155	995	800	550	290
SUPERSAND N 2000 / 23	20	15	400/50/3	2	30,0	2800	2700	2400	1980	1550	930		
SUPERSAND N 2000 4P / 23	20	15	400/50/3	4	30,0	6000	5500	4300	2040				

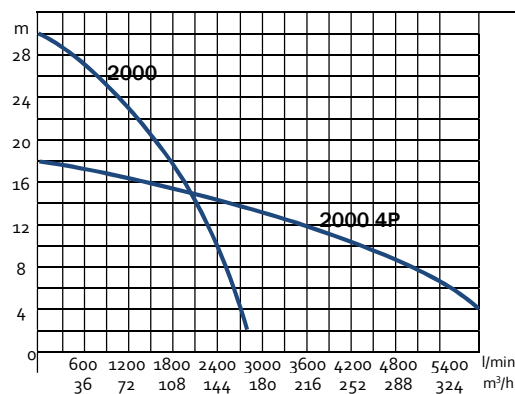
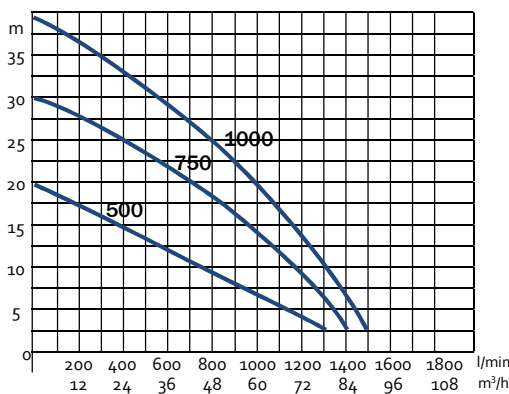
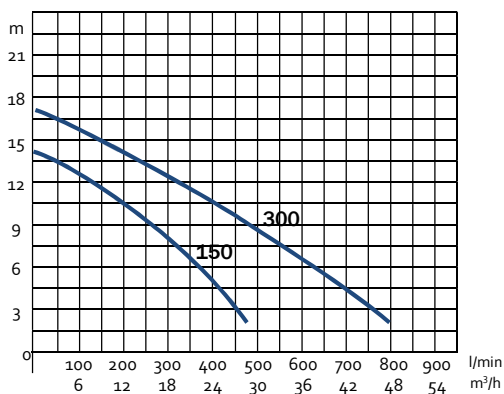

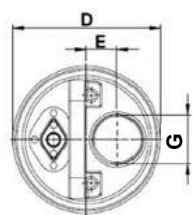
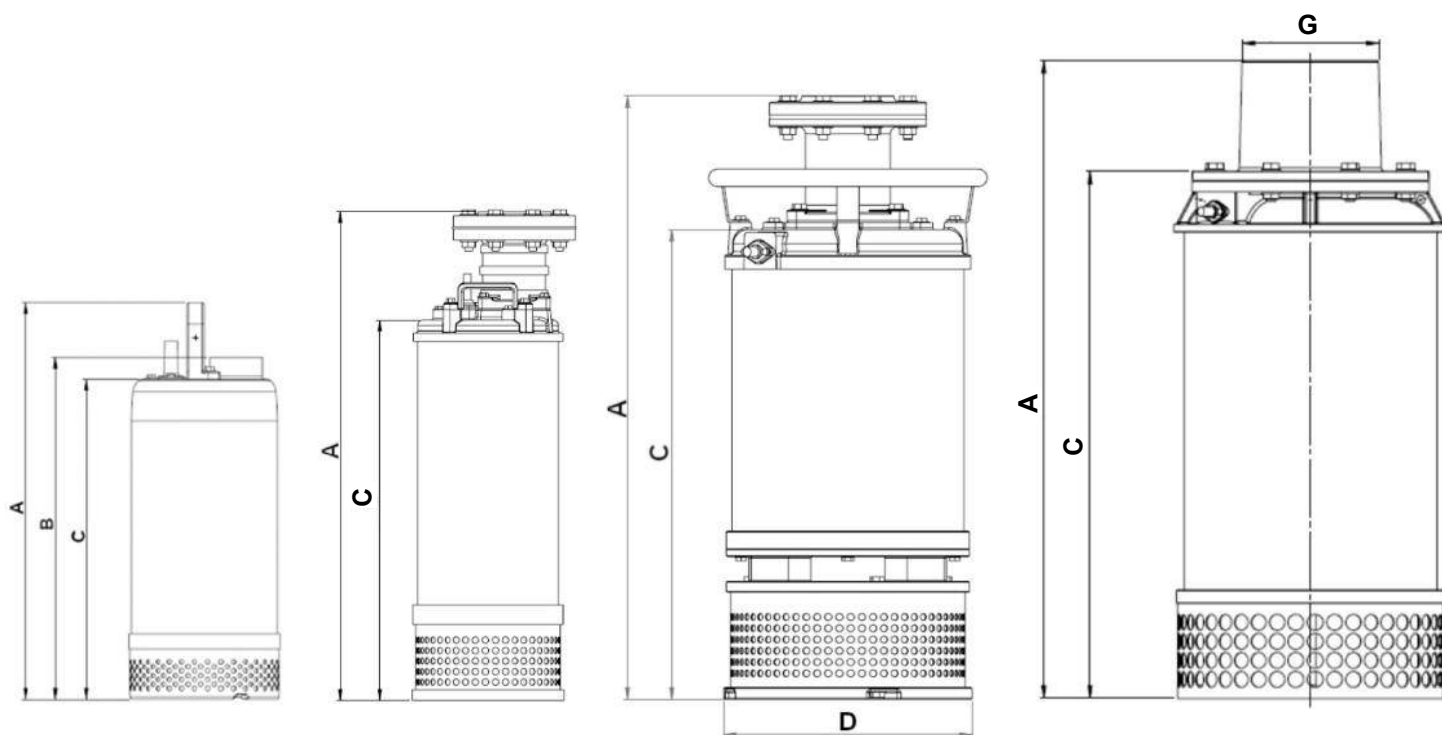

150

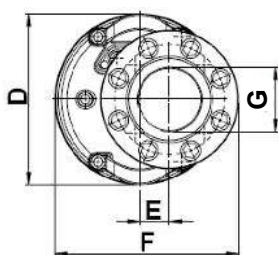

300
500

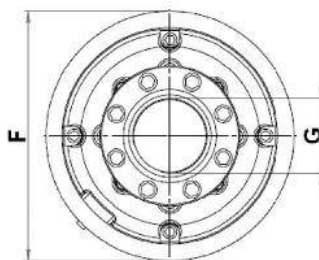

750
1000
2000

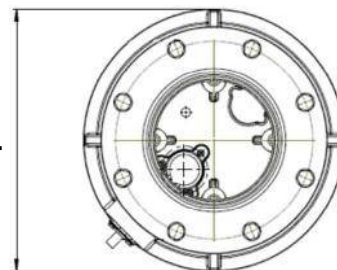

2000 - 4P

Modello Model	Mandata Discharge	Corpi solidi Solid parts	Dimensioni Dimensions mm							Peso Weight kg
			A	B	C	D	E	F	G	
SUPERSAND N 150 / 23	2" vertical	7	473	408	382	180	38	2"	24	
SUPERSAND N 300 / 23	3" - DN80 vertical	10	730	565	232	40	250	3"	58	
SUPERSAND N 500 / 23	3" - DN80 vertical	10	746	581	232	40	250	3"	63	
SUPERSAND N 750 / 23	4" - DN100 vertical	10	860	670	337	378	4"	110		
SUPERSAND N 1000 / 23	4" - DN100 Vertical	10	860	670	337	378	4"	113		
SUPERSAND N 2000 / 23	6" - DN150 vertical	15	918	760	337	378	6"	138		
SUPERSAND N 2000 4P / 23	DN200	25	1007	832	430	215	185			

POMPA PER POZZETTI STRETTI

PUMP FOR NARROW PITS



 Pompa sommergibile adatta al drenaggio di acque piovane o leggermente sporche. **Il sistema di avviamento con regolatore di livello fisso consente l'utilizzo della pompa anche in pozzetti stretti.** Robusta costruzione. Coperchio, cassa statore, corpo di mandata e supporto in ghisa. Girante aperta ed arretrata in ghisa di tipo "vortex", albero in acciaio inox. Motore a bagno d'olio con protezione termica incorporata. Tenuta meccanica in allumina/grafite. Cavo di 10 metri in neoprene H07RN8-F con spina. La scatola condensatore è posta all'estremità del cavo. Protezione IP 68. Isolamento classe F. Temperatura massima del liquido da pompare 40 °C; pH: 6 – 10; massima densità 1000 kg/m³.

 Submersible pump suitable for the drainage of rain water or slightly dirty water. **The automatic on-off system operating by a fixed level regulator with magnetic hook-up allows to use the pump also in narrow pits.** Heavy duty construction. Pump housing in cast iron. Back and open impeller "vortex" type in cast-iron. Shaft in stainless steel. Oil bathed motor with built-in motor protection. Mechanical seal in alumina/graphite. 10 metres supply cable H07RN8-F with plug. The capacitor box is placed at the end of the cable. Protection class IP 68. Insulation class F. Max temperature of the pumped liquid 104 °F (40 °C); pH: 6 – 10; max density 1000 kg/m³.

 Pompe submersible à tourbillon indiquée pour le drainage d'eaux pluviales ou un peu chargées. **Le régulateur de niveau fixe permet d'installer la pompe aussi dans des puits étroits.** Construction robuste. Corps de pompe en fonte. Roue "vortex" semi-ouverte en fonte. Arbre en acier inox. Moteur à bain d'huile avec protection thermique. Garniture mécanique en alumine/graphite. Câble électrique H07RN8-F de 10 mètres avec fiche. La boîte du condensateur est placée au bout du câble électrique. Protection IP 68. Isolation classe F. Température max. du liquide pompé 40 °C; pH: 6 – 10; densité max. 1000 kg/m³.

 Regenwasser und leicht Abwasser Tauchpumpe. **Fixniveaugler mit Durchflutungsgesetz-System.** Hergestellt aus hochwertigen und widerstandsfähigen Materialien. Pumpengehäuse aus Grauguß. "Vortex" Laufrad aus Grauguß. Antriebswelle aus rostfreiem Stahl. Ölgefüllter Tauchmotor mit thermischen Motorschutz. Gleitringdichtung aus Aluminiumoxyd/Graphit. 10 Meter Kabel H07RN8-F. IP 68 Schutz. Isol. Klasse F. Max. Temperatur der Flüssigkeit 40 °C; pH: 6 – 10; max. Dichte 1000 kg/m³.

Modello Model Modèle Modell	Potenza Power Puissance Pferdestärke		Tensione Voltage Bobinage Spannung	A	Prevalenza - Head - Hauteur - Förderhöhe (m)							
	HP	kW			V-Hz-ph	1	2	3	4	5	6	7
DRAIN 75	0,75	0,55	230-50-1	4,2	Portata - Capacity - Débit - Fördermenge (l/min)							
					225	205	188	165	139	105	63	4

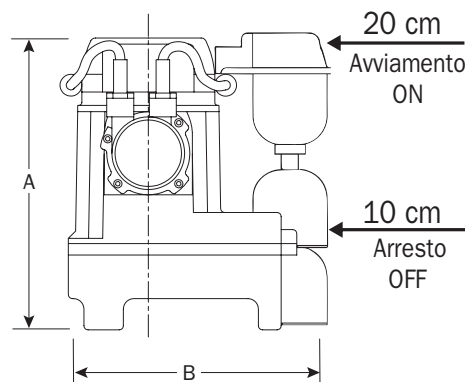
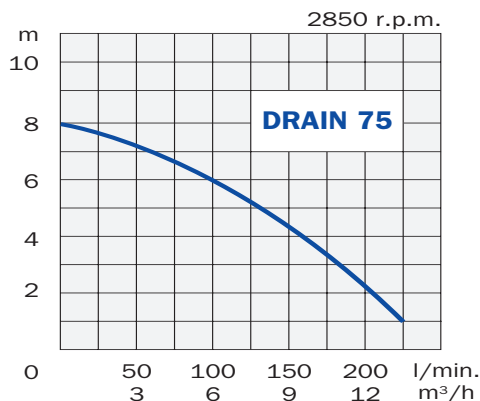

Modello Model Modèle Modell	Mandata Discharge Refoulement Druck-Seite	Dimensioni - Dimensions - Masstabelle			Peso Weight Poids Gewicht
		mm			
		A	B		kg
DRAIN 75	1"1/4 - DN 32 vertical	410	245	230 x 200 x H470	17

POMPA PER DRENAGGIO FINO A 2mm

PUMP FOR DRAINAGE UP TO 2mm

ASPIRA 50



Pompa sommergibile per il drenaggio di acque pulite. Con il galleggiante bloccato in posizione "ON", il particolare sistema di aspirazione consente di aspirare l'acqua fino a soli 2 millimetri d'altezza dal suolo. Ciò rende questo modello adatto al prosciugamento di locali allagati sprovvisti di pozzetto di raccolta. Carcassa in acciaio inox, girante in plastica. La pompa è corredata di 10 metri di cavo di alimentazione con spina. Protezione IP 68. Classe isolamento F. Temperatura massima del liquido da pompare 35 °C; pH: 6 – 10; densità massima: 1000 kg/m³.

Submersible pump suitable for the drainage of clean water. With the float-switch placed in "ON" position, the particular suction system permits to suck water up to only 2 millimetres from the ground level. That makes this model ideal for the drainage of flooded rooms without a pit. External case in stainless steel, plastic impeller. The pump is supplied with 10 metres cable with plug. Protection IP 68. Insulation class F. Maximum temperature of the pumped liquid 95 °F (35 °C); pH: 6 – 10; max density 1000 kg/m³.

Pompe submersible pour le drainage d'eau claire. Avec le flotteur mis en position "ON", l'original système d'aspiration permet de aspirer l'eau jusqu'à un niveau de seulement 2 millimètres d'hauteur du plancher. Partant cette pompe est très indiquée pour assécher les caves ou d'autres locaux où il n'y a pas un puits collecteur des eaux de pluie. Corps de pompe en acier inox, roue de type ouverte en plastique. 10 mètres de câble électrique avec fiche. Protection IP 68. Isolation class F. Température max. de l'eau pompée 35° C; pH: 6 – 10; densité max: 1000 kg/m³.

Tauchpumpe für die Drainage von sauberem Wasser. Mit dem Schwimmschalter in "ON" Stellung, das spezielle Ansaugsystem ermöglicht ein Absaugen von bis zu 2 Millimeter von der Bodenhöhe. Dadurch zeichnet sich dieses Modell für die Drainage von überfluteten Räumen ohne Ablaufschacht besonders aus. Gehäuse ist aus Edelstahl und das Laufrad aus Kunststoff. Die Pumpe wird mit 10 Meter Kabel und Stecker geliefert. IP 68 Schutz. Isol. Klasse F. Maximaltemperatur der Flüssigkeit: 35 °C; pH: 6 – 10; Max Dichte: 1000 kg/m³.

Modello Model Modèle Modell	Potenza Power Puissance Pferdestärke		Tensione Voltage Bobinage Spannung	A	Prevalenza - Head - Hauteur - Förderhöhe (m)						
	HP	kW			1	2	3	4	5	6	7
ASPIRA 50	0,5	0,37	230-50-1	1,5	Portata - Capacity - Débit - Fördermenge (l/min)						
					130	110	88	68	45	21	2

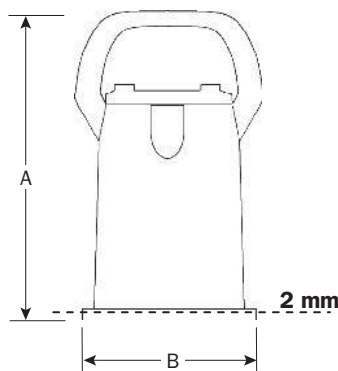
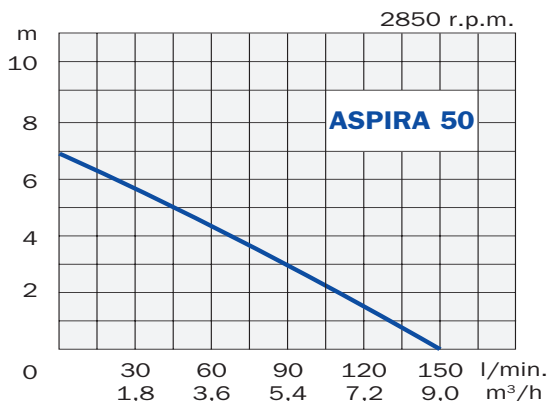

ATTENZIONE: le prestazioni si riducono con la pompa appoggiata al suolo **ATTENTION: the performance gets reduced when the pump lays on the ground**

Modello Model Modèle Modell	Mandata Discharge Refoulement Druck-Seite	Dimensioni - Dimensions - Masstabelle			Peso Weight Poids Gewicht
		mm			
		A	B		kg
ASPIRA 50	1"1/4 - DN 32 vertical	285	160	220 x 165 x H310	4

POMPE AERATRICI

AERATOR PUMPS

AIR INJECTOR



L'aeratore è utilizzato per l'ossigenazione di acque reflue e nella piscicoltura. L'aria viene aspirata tramite un tubo e si miscela con l'acqua pompata. La particolare camera di miscelazione produce bolle d'aria di dimensioni molto piccole che consentono un elevato scambio di ossigeno. Robusta costruzione. Coperchio, cassa statore, corpo di mandata e supporto in ghisa. Girante in ghisa. Albero in acciaio inox AISI 403. Doppia tenuta meccanica in carburo di silicio in camera d'olio. Cavo di alimentazione di 10 metri in neoprene H07RNF. Tensione trifase. Protezione a cura dell'utente. Protezione IP68. Isolamento classe F. Temperatura massima del liquido da pompare 40 °C; pH: 6 – 10; massima densità del liquido 1000 kg/m³.

Attenzione: il tubo di aspirazione dell'aria non viene fornito.

The aerator is particularly used in the fields of water treatment and fish farms. The air is in taken through a tube and mixed with the pumped water. The special mixing room produces very little air bubbles allowing a high exchange of oxygen. The pump has an heavy duty construction. Pump housing in cast-iron. Impeller in cast-iron. Shaft in stainless steel AISI 403. Double mechanical seal in silicon-carbide in oil chamber. 10 metres supply cable H07RNF. Three-phase voltage. The pump must be protected by a fused remote isolator switch. Protection IP68. Insulation class F. Max temperature of pumped liquid 104 °F (40 °C); pH: 6 – 10; max density of the liquid: 1000 kg/m³.

Attention: the air intake tube is not supplied.

L'aérateur est employé pour le traitement des eaux résiduaires ainsi que dans le domaine de la pisciculture. L'air est aspiré par un tuyau et dans la chambre de mélange se forment de petites bulles d'air qui permettent un échange d'oxygène très élevé. Construction robuste. Couvercle, corps de pompe, corps de refoulement et support en fonte. Roue en fonte. Arbre en acier inox AISI 403. Double garniture mécanique en carbure de silicium en chambre d'huile. Câble électrique H07RNF de 10 mètres. Bobinage triphasé. Protection par l'utilisateur. Protection IP 68. Isolation classe F. Température max. du liquide pompé: 40 °C; pH: 6 – 10; densité max. du liquide pompé: 1000 Kg/m³.

Attention: le tuyau d'aspiration de l'air n'est pas fourni.

Der Belüfter wird für die Sauerstoffzufuhr bei Abwässern und in der Fischzucht verwendet. Die Luft wird über einen Schlauch angesaugt und mit dem gepumpten Wasser vermischt. Die spezielle Mischkammer bildet besonders kleine Luftblasen, die einen starken Sauerstoffaustausch ermöglichen. Kräftige Bauweise. Deckel, Statorgehäuse, Fördergehäuse und Träger aus Grauguß. Laufrad aus Grauguß. Antriebswelle aus rostfreiem Stahl AISI 403. Ölgekühlte Doppel-Gleitringdichtung aus SiliziumKamid. 10 Meter Kabel H07RNF. Dreiphasenspannung. Motorvollschutz nach Benutzersorge. IP 68 Schutz. Isol. Klasse F. Max. Temperatur der Flüssigkeit: 40 °C; pH: 6 – 10; Max. Dichte: 1000 kg/m³.

Achtung: Der Luftsaugschlauch wird nicht mitgeliefert.

Modello Model Modèle Modell	Potenza Power Puissance Pferdestärke		Tensione Voltage Bobinage Spannung V-Hz-ph	Giri/min R.p.m. Tours/min U./min	A	Profondità pompa - Pump depth Profondeur pompe - Pumpetiefe (m)				
	HP	kW				Aria immessa - Air injected - Air introduit Eingeführte Luft (m ³ /h)				
						1	2	3	4	5
AIR INJECTOR 400	4	3	400-50-3	2840	5,0	50	44	38	37	
AIR INJECTOR 550	5,5	4	400-50-3	1400	8,8	125	94	70	65	65

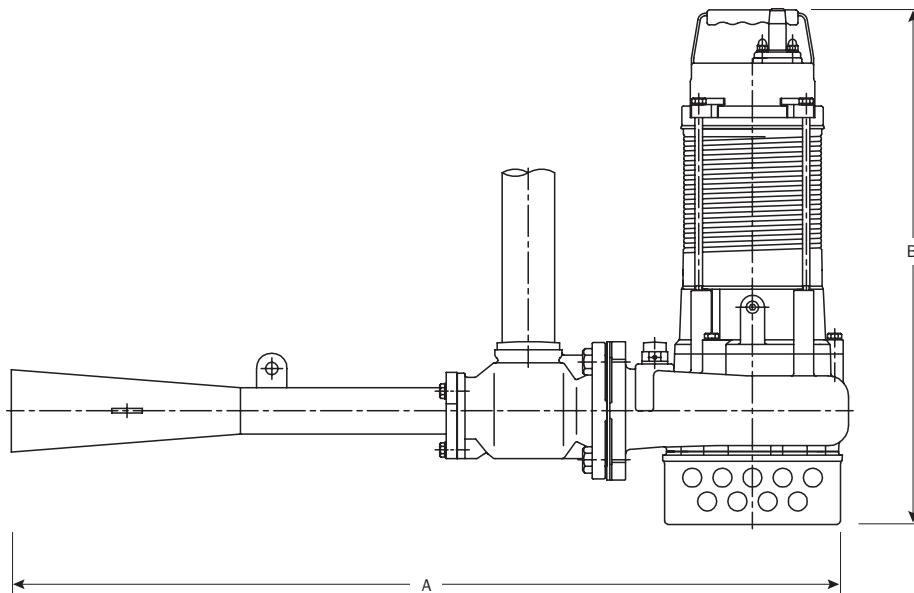
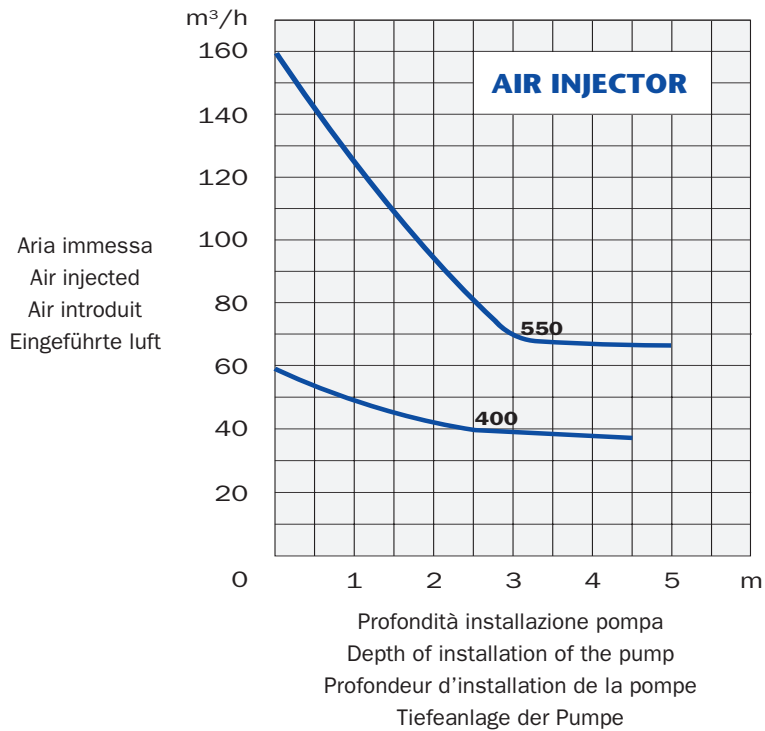

Modello Model Modèle Modell	Tubo aspirazione Intake tube Tuyau d'aspiration Ansaugschlauch	Max profondità Max depth Profondeur max Max Tauchtiefe m	Corpi solidi Solid parts Corps solides Festkörper mm	Dimensioni pompa Pump dimensions Dimensions pompe Pumpemasstabelle mm		Peso Weight Poids Gewicht kg	Max dim. vasca Max tank dim. Dim. max cuve Max. Behältermasstabelle m
				A	B		
AIR INJECTOR 400	1" 1/4 - DN 32	4,5	20	870	555	45	4 x 4 x H4,5
AIR INJECTOR 550	2" - DN 50	5	20	1130	630	85	6 x 6 x H5

POMPE SOMMERSE PER USO DOMESTICO

SUBMERGED PUMPS FOR DOMESTIC USE

WELL P 100 BRASS - 4"



WELL C 80-150 - 5"



Pompe sommerse per uso domestico adatte al pompaggio di acqua pulita. Albero motore in acciaio inox AISI 420. Doppia tenuta meccanica in bagno d'olio. Isolamento classe B. Protezione: IP 68. Temperatura massima dell'acqua da pompare 30 °C. Il modello **WELL P 100 BRASS** ha corpo mandata e girante periferica in ottone, motore a bagno d'olio, cavo di alimentazione da 15 metri con control box, condensatore e protezione a riarmo manuale posizionati alla fine del cavo. I modelli **WELL C** hanno giranti in noryl e cavo di alimentazione da 15 metri con control box, condensatore e protezione a riarmo manuale posizionati alla fine del cavo. Disponibili con o senza galleggiante.

Submerged pumps for domestic use suitable to pump clean water. Motor shaft in stainless steel AISI 420. Double mechanical seal in oil chamber. Insulation class B. Protection class: IP 68. Max. temperature of the pumped liquid 86 °F (30 °C). The model **WELL P 100 BRASS** has discharge body and peripheral impeller in brass, oil bathed motor, 15 metres supply cable, control box with capacitor and manual reset protection positioned at the end of the cable. The models **WELL C** have noryl impellers, 15 metres supply cable, control box with capacitor and manual reset protection positioned at the end of the cable. Available with or without float-switch.

Pompes de forage pour le pompage d'eau claire. Arbre moteur en acier inox AISI 420. Double garniture mécanique en chambre d'huile. Isolation classe B. Protection: IP 68. Température max. de l'eau pompée 30 °C. Le modèle **WELL P 100 BRASS** a corps de refoulement et roue périphérique en laiton, moteur à bain d'huile, câble électrique de 15 mètres, control box avec condensateur et protection à réarmement manuel à la fin du câble. Les modèles **WELL C** ont roues en noryl, câble électrique de 15 mètres, control box avec condensateur et protection à réarmement manuel à la fin du câble. Disponibles avec ou sans flotteur.

Unterwasserpumpen für die Hauswasserversorgung für das saubere Wasser. Antriebswelle aus rostfreiem Stahl AISI 420. Ölgekühlte Doppel-Gleitringdichtung. Isol. Klasse B. IP 68 Schutz. Max. Temperatur der Flüssigkeit 30 °C. Modell **WELL P 100 BRASS**: Auslaßgehäuse und Peripheralrad aus Messing, Ölgekühlter Tauchmotor, Schutzvorrichtung mit manueller Rückstellung im Netzkabel. 15 Meter Kabel H07RNF. Modellen **WELL C**: Laufräder aus Noryl, Schutzvorrichtung mit manueller Rückstellung im Netzkabel. 15 Meter Kabel H07RNF. Mit oder ohne schwimmerschalter.

Modello Model Modèle Modell	Potenza Power Puissance Pferdestärke		Tensione Voltage Bobinage Spannung V-Hz-ph	A	Numero stadi Number stages Nombre étages Stufenzahl N.	Portata - Capacity - Débit - Fördermenge (l/min)														
	HP	kW				10	20	30	40	50	60	70	80	90	100					
	Prevalenza - Head - Hauteur - Förderhöhe (m)																			
WELL P 100 BRASS	1	0,75	230-50-1	6,0	1	49	40	29	19	8										
WELL C 80	0,8	0,59	230-50-1	4,4	4	47	44	42	38	35	32	27	23	19	12					
WELL C 150	1,5	1,1	230-50-1	6,5	7	65	60	56	52	48	43	37	32	25	19					

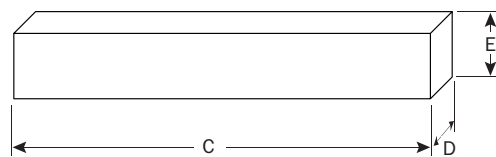
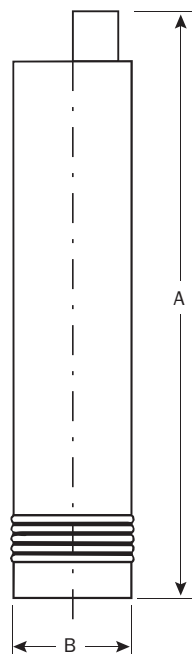
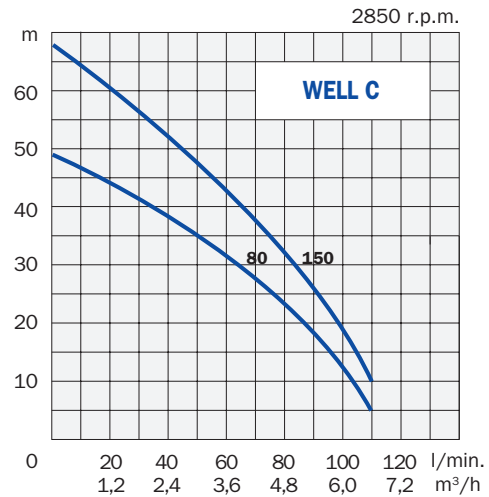
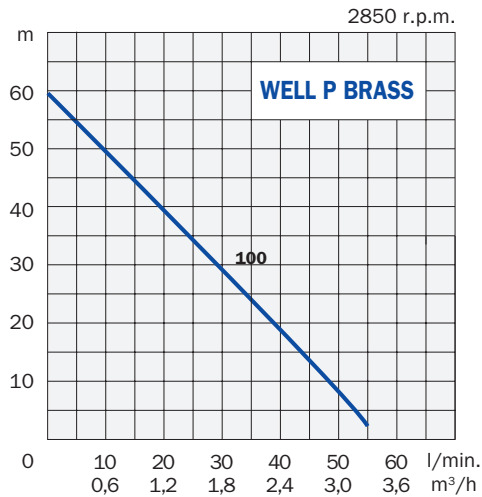

Modello Model Modèle Modell	Mandata Discharge Refoulement Druck-Seite	Dimensioni - Dimensions - Masstabelle					Peso Weight Poids Gewicht kg
		mm					
		A	B	C	D	E	
WELL P 100 BRASS	1" - DN 25	495	95 (4")	585	265	290	14
WELL C 80	1"1/4 - DN 32	500	128 (5")	615	270	200	15
WELL C 150	1"1/4 - DN 32	570	128 (5")	615	270	200	19

POMPE SOMMERSE 3"

SUBMERGED PUMPS 3"

WELL D



-  Pompe sommerse per il prelievo di acqua pulita da pozzi profondi per irrigazione, per usi domestici o industriali.
Flangia di accoppiamento al motore e bocca di mandata in ottone, giranti in noryl e diffusori in poliacetato. Valvola di non ritorno incorporata. Camicia pompa e filtro in acciaio inox.
Motore sommerso a bagno d'olio. Albero motore in acciaio inox. Protezione IP 68. Isolamento classe F.
Temperatura max. dell'acqua 35 °C. Contenuto max. di sabbia 40 gr/m³.

-  Submerged pumps suitable to pump clean water from deep wells for irrigation, for domestic or industrial use.
Hydraulic part bracket and discharge head in brass, impellers in noryl and diffusers in polyacetal. Built-in non-return valve. Pump case and strainer in stainless steel. Oil bathed motor. Motor shaft in stainless steel. Protection class IP 68. Insulation class F.
Max. temperature of water 95 °F (35 °C). Max. contents of sand 40 gr/m³.

-  Pompes de forage pour pomper l'eau propre de puits, indiquées pour installations civiles et industrielles et pour systèmes d'irrigation.
Bride de la partie hydraulique et pièce de refoulement en laiton, roues en noryl et diffuseurs en polyacetal. Clapet anti-retour incorporé. Chemise extérieure et crépine en acier inox.
Moteur lubrifié par huile. Arbre moteur en acier inox. Protection IP 68. Isolation classe F.
Température max. de l'eau 35 °C. Max. contenu de sable 40 gr/m³.

-  Tauchpumpen für die Entnahme von sauberem Wasser aus tiefen Brunnen für den Zivilgebrauch, für die Beregnung und viele andere Verwendungszwecke.
Flanschanschluss und Auslaßgehäuse aus Messing, Flügelräder aus Noryl und Diffusoren aus Polyacetal. Rückschlagventil aus Noryl. Gehäusemantel und Filter aus rostfreiem Stahl.
Ölbadauchmotor. Antriebswelle aus rostfreiem Stahl. IP 68 Schutz. Isol. Klasse F.
Max. Temperatur der Flüssigkeit: 35 °C. Max. Sanddichte 40 gr/m³.

Modello Model Modèle Modell	Potenza Power Puissance Pferdestärke		Tensione Voltage Bobinage Spannung V-Hz-ph	A	Nr. stadi N. stages N. étages Stufenzahl N.	Portata - Capacity - Débit - Fördermenge (l/min)					
	HP	kW				0	10	20	30	40	45
	Prevalenza - Head - Hauteur - Förderhöhe (m)										
WELL D 75	0,75	0,55	230-50-1	5,1	23	72	67	55	39	18	4
			400-50-3	2,3							
WELL D 100	1	0,75	230-50-1	6,2	30	90	84	71	55	30	16
			400-50-3	3,1							
WELL D 150	1,5	1,1	230-50-1	8,5	45	130	119	100	76	45	28
			400-50-3	3,4							

*On request other voltages are available

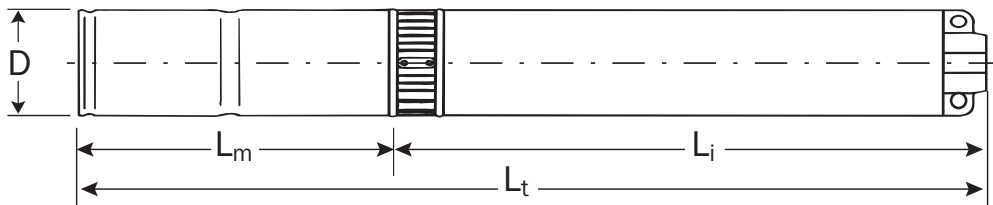
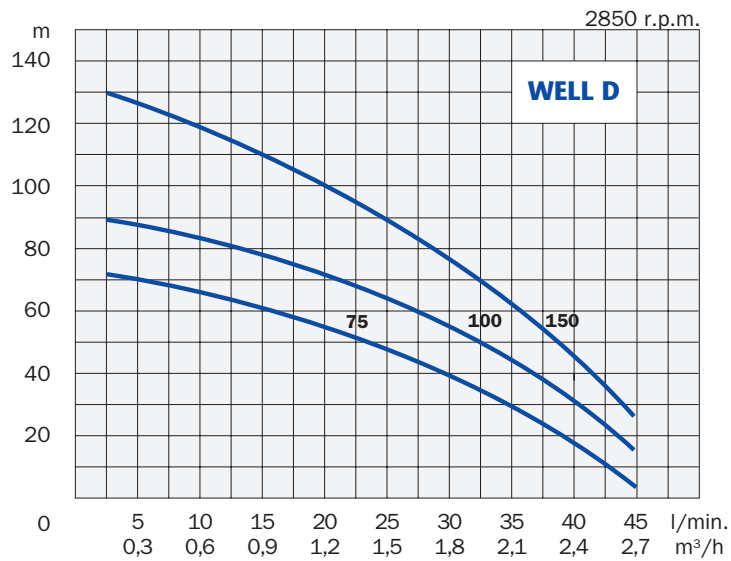

Modello Model Modèle Modell	Tensione Voltage Bobinage Spannung	Mandata Discharge Refoulement Druck-Seite	Dimensioni Dimensions Masstabelle mm				Peso - Weight - Poids - Gewicht kg		
			D	L _m	L _i	L _t	Motor Motor Moteur Motor	Pompa Pump Pompe Pumpe	Totale Total Totale Total
WELL D 75	230/50/1	1" - DN 25	74 (3")	458	780	1207	7,7	4,4	12,1
	400/50/3			458		1207	7,5		11,9
WELL D 100	230/50/1	1" - DN 25	74 (3")	477	1000	1447	8,3	5,6	13,9
	400/50/3			458		1427	7,7		13,3
WELL D 150	230/50/1	1" - DN 25	74 (3")	528	1380	1877	9,4	7,6	17,0
	400/50/3			528		1877	9,7		17,0

POMPE SOMMERSE 4"

SUBMERGED PUMPS 4"

WELLS



 Pompe sommerse per il prelievo di acqua da pozzi profondi per uso civile, per irrigazioni a pioggia, per fontane e per molti altri impieghi.

Diffusori in policarbonato anticorrosione ed atossico, giranti in Noryl. **Le giranti sono di tipo flottante e quindi molto resistenti all'abrasione della sabbia.** Camicia pompa, corpo aspirazione, corpo mandata e valvola di ritegno in acciaio inox.

Motore sommerso a bagno d'acqua o a bagno d'olio. Albero motore in acciaio inox. Protezione IP 68. Isolamento classe F. Temperatura massima dell'acqua da pompare: 35 °C. Contenuto massimo di sabbia per la parte idraulica: 180 gr/m³.

Disponibili anche con inverter a frequenza variabile.



Submerged pumps suitable to pump clean water from deep wells and tanks for domestic, commercial and industrial use, as well as for irrigation and sprinkling systems.

Diffusers in corrosion resistant non-toxic polycarbonate, impellers in Noryl. **The impellers are floating type much resistant to abrasion of sand.** Pump housing, suction casing, discharge casing and built-in check valve in stainless steel.

Water bathed or oil bathed submerged motor. Motor shaft in stainless steel. Protection class IP 68. Insulation class F. Max. temperature of pumped water 95 °F (35 °C). Max content of sand for the hydraulic part: 180 gr/m³.

Available also with variable-frequency inverter.



Pompes de forage pour pomper l'eau propre de puits, de réservoirs ou de bassins naturels. Indiquées pour le relevage, la surpression et la distribution d'eau dans des installations civiles et industrielles et pour systèmes d'irrigation.

Diffuseurs en polycarbonate résistant à la corrosion et non toxique, roues en Noryl. **Les roues sont de type flottant très résistants à l'abrasion du sable.** Chemise extérieure, corps d'aspiration, corps de refoulement et soupape de retenue en acier inox.

Moteurs lubrifiés par eau ou par huile. Arbre en acier inox. Protection IP 68. Isolation classe F. Température max. de l'eau 35 °C. Max contenu de sable pour la partie hydraulique: 180 gr/m³.

Les pompes sont disponibles aussi avec inverter à fréquence variable.



Tauchpumpen für die Entnahme von sauberem Wasser aus tiefen Brunnen für den Zivilgebrauch, für die Beregnung, für Brunnen und viele andere Verwendungszwecke.

Diffusoren aus korrosionsfestem und ungiftigem Polykarbonat, Flügelräder aus Noryl. **Die Flügelräder sind schwimmend und sehr beständig wegen Sandfestigkeit.**

Pumpenverkleidung, Eingangs und Ausgaskörper sowie das Rückschlagventil der Pumpen aus Edelstahl.

Wasser-oder ölgekühlter Tauchmotor. Antriebswelle aus Edelstahl. IP 68 Schutz. Isol. Klasse F. Max Temperatur der Flüssigkeit: 35 °C. Max Sanddichte für den hydraulischen Pumpenteil 180 gr/m³.

Die Pumpen sind auch mit Wechsellastfrequenz-Inverter lieferbar.

Modello Model Modèle Modell	Potenza Power Puissance Pferdestärke		Tensione Voltage Bobinage Spannung	A	Nr. stadi N. stages N. étages Stufenzahl	Prevalenza - Head - Hauteur - Förderhöhe (m)							
WELL S3						Portata - Capacity - Débit - Fördermenge (l/min)							
	HP	kW	V-Hz-ph	A.	N.	0	10	20	25	30	35	40	50
WELL S3-50	0,5	0,37	230-50-1 400-50-3	3,6 1,8	7	44	42	40	38	35	32	29	20
WELL S3-75	0,75	0,55	230-50-1 400-50-3	4,7 2,0	10	70	67	62	59	54	50	44	30
WELL S3-100	1,0	0,75	230-50-1 400-50-3	5,9 2,5	14	93	90	84	80	75	69	62	45
WELL S3-150	1,5	1,1	230-50-1 400-50-3	8,3 3,4	20	140	135	125	118	110	101	90	60
WELL S4						Portata - Capacity - Débit - Fördermenge (l/min)							
	HP	kW	V-Hz-ph	A.	N.	0	10	20	30	40	50	60	70
WELL S4-75	0,75	0,55	230-50-1 400-50-3	4,7 2,0	8	52	50	47	43	39	32	25	16
WELL S4-100	1,0	0,75	230-50-1 400-50-3	5,9 2,5	11	70	69	66	62	57	50	39	23
WELL S4-150	1,5	1,1	230-50-1 400-50-3	8,3 3,4	16	103	100	95	88	80	68	52	30
WELL S4-200	2,0	1,5	230-50-1 400-50-3	10,7 4,8	21	140	137	132	125	113	99	78	47
WELL S6						Portata - Capacity - Débit - Fördermenge (l/min)							
	HP	kW	V-Hz-ph	A.	N.	0	15	30	45	60	75	90	100
WELL S6-100	1,0	0,75	230-50-1 400-50-3	5,9 2,5	9	60	59	57	52	43	34	20	13
WELL S6-150	1,5	1,1	230-50-1 400-50-3	8,3 3,4	14	97	94	88	80	69	54	34	23
WELL S6-200	2,0	1,5	230-50-1 400-50-3	10,7 4,8	18	120	118	113	105	93	75	50	36
WELL S6-300	3,0	2,2	230-50-1 400-50-3	15,2 6,1	27	176	170	160	147	128	105	69	42
WELL S6-400	4,0	3,0	400-50-3	7,1	35	228	225	214	199	174	140	88	57
WELL S6-550	5,5	4,0	400-50-3	9,2	48	324	310	289	260	226	180	117	75
WELL S9						Portata - Capacity - Débit - Fördermenge (l/min)							
	HP	kW	V-Hz-ph	A.	N.	0	20	40	60	80	100	120	140
WELL S9-150	1,5	1,1	230-50-1 400-50-3	8,3 3,4	10	60	56	52	47	40	33	24	13
WELL S9-200	2,0	1,5	230-50-1 400-50-3	10,7 4,8	14	89	85	78	73	62	52	39	24
WELL S9-300	3,0	2,2	230-50-1 400-50-3	15,2 6,1	20	124	118	111	102	90	79	62	39
WELL S9-400	4,0	3,0	400-50-3	7,1	27	168	157	146	133	117	100	79	52
WELL S9-550	5,5	4,0	400-50-3	9,2	36	221	208	196	181	162	140	112	74
WELL S9-750	7,5	5,5	400-50-3	12,3	49	302	288	269	246	220	190	151	96
WELL S12						Portata - Capacity - Débit - Fördermenge (l/min)							
	HP	kW	V-Hz-ph	A.	N.	0	50	75	100	125	150	175	200
WELL S12-200	2,0	1,5	230-50-1 400-50-3	10,7 4,8	8	53	50	48	43	41	37	31	25
WELL S12-300	3,0	2,2	230-50-1 400-50-3	15,2 6,1	13	81	78	75	69	64	57	45	33
WELL S12-400	4,0	3,0	400-50-3	7,1	17	110	107	100	94	85	74	61	44
WELL S12-550	5,5	4,0	400-50-3	9,2	23	148	140	133	124	113	98	80	60
WELL S12-750	7,5	5,5	400-50-3	12,3	32	202	191	181	169	156	137	113	83
WELL S24						Portata - Capacity - Débit - Fördermenge (l/min)							
	HP	kW	V-Hz-ph	A.	N.	0	100	150	200	250	300	350	400
WELL S24-400	4,0	3,0	400-50-3	7,1	11	67	55	50	43	37	29	22	13
WELL S24-550	5,5	4,0	400-50-3	9,2	15	93	80	73	65	55	46	34	21
WELL S24-750	7,5	5,5	400-50-3	12,3	20	124	117	97	87	75	62	49	34
WELL S24-1000	10,0	7,5	400-50-3	16,4	26	160	138	126	112	99	84	68	50

*On request other voltages are available

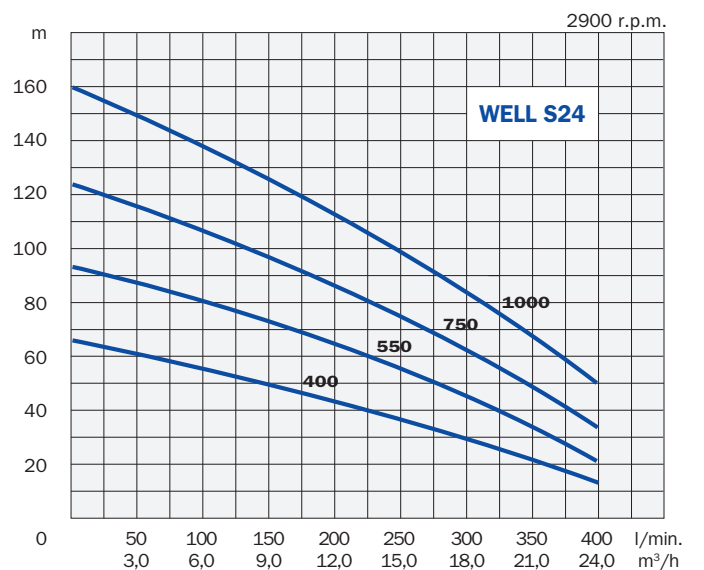
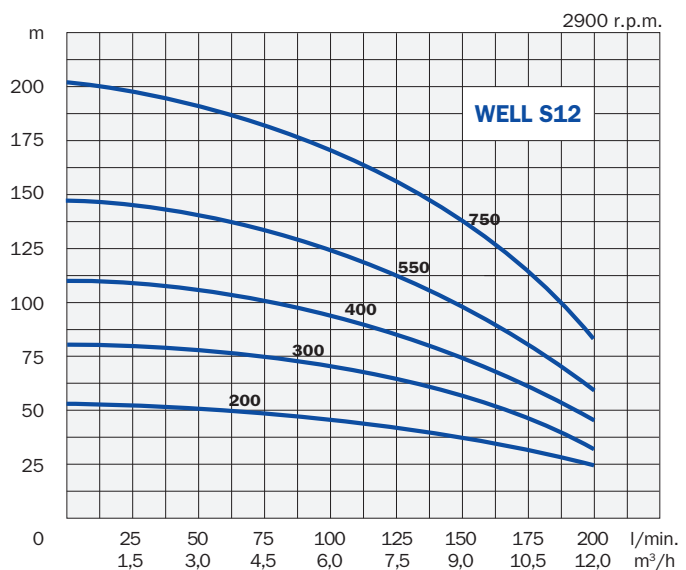
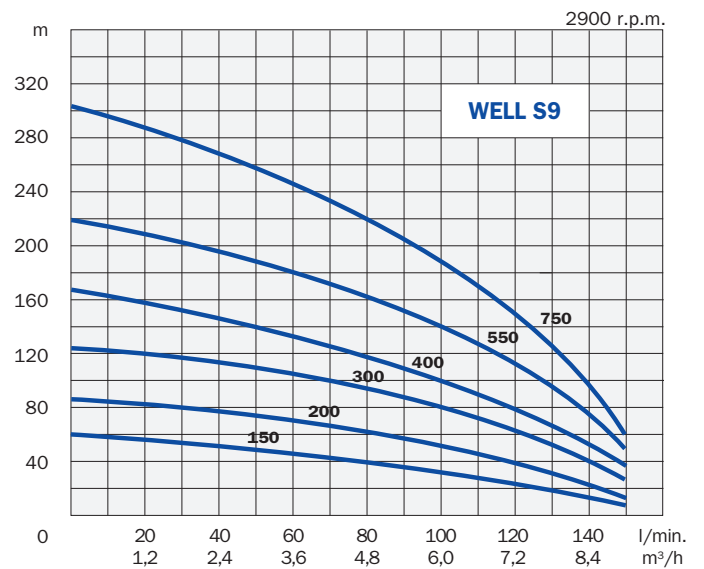
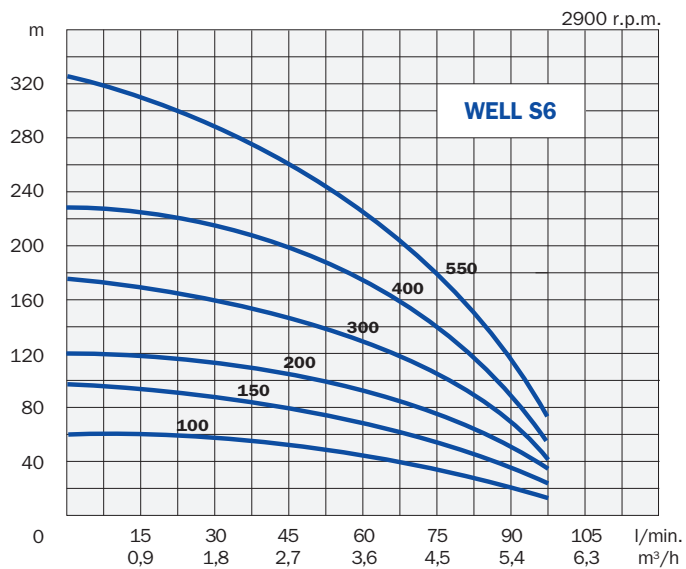
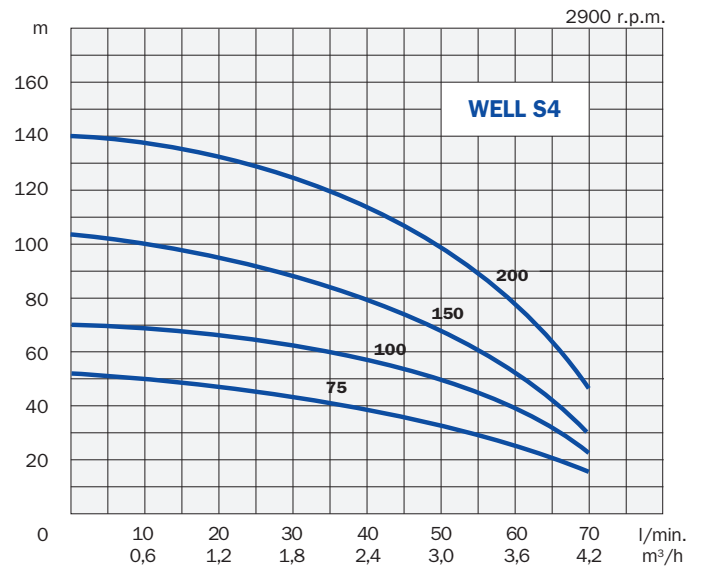
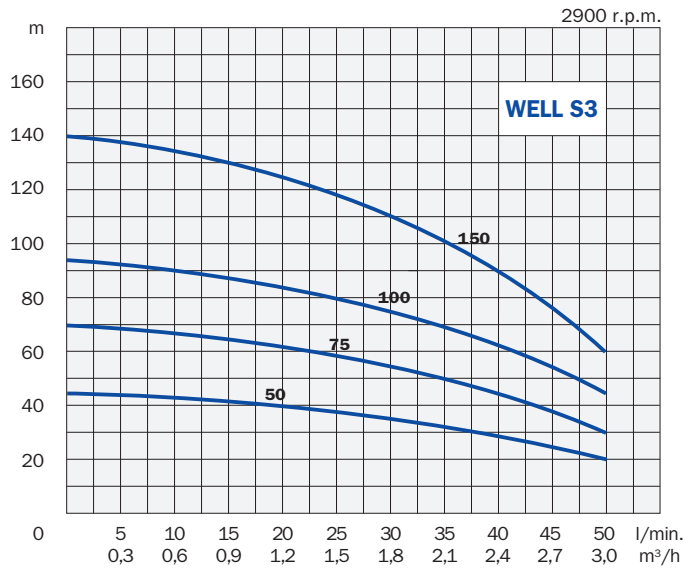

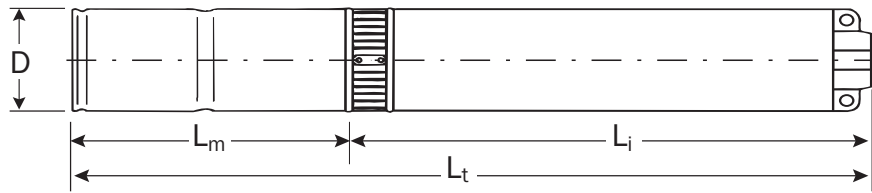

Modello Model Modèle Modell	Tensione Voltage Bobinage Spannung V-Hz-ph	Mandata Discharge Refoulement Druck-Seite	Dimensioni Dimensions Masstabelle mm				Peso - Weight - Poids - Gewicht kg		
			D	L _m	L _i	L _t	Motor Motor Moteur Motor	Pompa Pump Pompe Pumpe	Totale Total Totale Total
WELL S3-50	230-50-1	1"1/4 - DN 32	98 (4")	350	271	583	6,5	2,8	9,3
	400-50-3								
WELL S3-75	230-50-1	1"1/4 - DN 32	98 (4")	370	324	656	7,0	3,3	10,3
	400-50-3								
WELL S3-100	230-50-1	1"1/4 - DN 32	98 (4")	395	394	751	8,5	3,9	12,4
	400-50-3								
WELL S3-150	230-50-1	1"1/4 - DN 32	98 (4")	425	499	886	10,0	4,9	14,9
	400-50-3			410		871			9,5
WELL S4-75	230-50-1	1"1/4 - DN 32	98 (4")	370	289	621	7,0	2,9	9,9
	400-50-3								
WELL S4-100	230-50-1	1"1/4 - DN 32	98 (4")	395	342	699	8,5	3,4	11,9
	400-50-3								
WELL S4-150	230-50-1	1"1/4 - DN 32	98 (4")	425	430	817	10,0	4,2	14,2
	400-50-3			410		802			9,5
WELL S4-200	230-50-1	1"1/4 - DN 32	98 (4")	475	519	956	11,5	5,0	16,5
	400-50-3			425		906			10,0
WELL S6-100	230-50-1	1"1/4 - DN 32	98 (4")	395	344	701	8,5	3,3	11,8
	400-50-3								
WELL S6-150	230-50-1	1"1/4 - DN 32	98 (4")	425	452	839	10,0	4,1	14,1
	400-50-3			410		824			9,5
WELL S6-200	230-50-1	1"1/4 - DN 32	98 (4")	475	538	975	11,5	4,7	16,2
	400-50-3			425		925			10,0
WELL S6-300	230-50-1	1"1/4 - DN 32	98 (4")	520	767	1249	15,0	6,2	21,2
	400-50-3			475		1204			11,5
WELL S6-400	400-50-3	1"1/4 - DN 32	98 (4")	489	934	1384	15,0	7,9	22,9
WELL S6-550	400-50-3	1"1/4 - DN 32	98 (4")	544	1253	1758	20,0	9,9	29,9
WELL S9-150	230-50-1	2" - DN 50	98 (4")	425	483	870	10,0	4,6	14,6
	400-50-3			410		855			9,5
WELL S9-200	230-50-1	2" - DN 50	98 (4")	475	607	1044	11,5	5,7	17,2
	400-50-3			425		994			10,0
WELL S9-300	230-50-1	2" - DN 50	98 (4")	520	831	1313	15,0	7,5	22,5
	400-50-3			475		1268			11,5
WELL S9-400	400-50-3	2" - DN 50	98 (4")	489	1048	1498	15,0	9,6	24,6
WELL S9-550	400-50-3	2" - DN 50	98 (4")	544	1318	1823	15,2	12,2	27,4
WELL S9-750	400-50-3	2" - DN 50	98 (4")	627	1802	2391	20,0	15,9	35,9
WELL S12-200	230-50-1	2" - DN 50	98 (4")	475	418	855	11,5	4,0	15,5
	400-50-3			425		805			10,0
WELL S12-300	230-50-1	2" - DN 50	98 (4")	520	573	1055	15,0	5,5	20,5
	400-50-3			475		1010			11,5
WELL S12-400	400-50-3	2" - DN 50	98 (4")	489	697	1147	15,0	6,6	21,6
WELL S12-550	400-50-3	2" - DN 50	98 (4")	544	921	1426	15,2	8,4	23,6
WELL S12-750	400-50-3	2" - DN 50	98 (4")	627	1238	1827	20,0	11,0	31,0
WELL S24-400	400-50-3	2" - DN 50	98 (4")	489	880	1330	15,0	8,1	23,1
WELL S24-550	400-50-3	2" - DN 50	98 (4")	544	1149	1654	15,2	10,5	25,7
WELL S24-750	400-50-3	2" - DN 50	98 (4")	627	1489	2078	20,0	13,5	33,5
WELL S24-1000	400-50-3	2" - DN 50	98 (4")	838	1810	2610	29,0	17,9	46,9

POMPE SOMMERSE RADIALI 6"

SUBMERGED RADIAL PUMPS 6"

WELL R



 Pompe sommerse adatte al prelievo di acqua pulita da pozzi profondi per uso civile, per irrigazioni a pioggia, per fontane e per molti altri impieghi. Ottimo rendimento.

Corpo di mandata e flangia di accoppiamento al motore in ottone. Giranti e diffusori in Noryl. Valvola di ritegno incorporata. Albero e camicia pompa in acciaio inox.

Motore sommerso a bagno d'acqua o a bagno d'olio con parasabbia. Tensione trifase, con protezione a cura dell'utente. Protezione IP 58. Isolamento classe F. Contenuto massimo di sabbia 40 gr/m³. Temperatura massima dell'acqua da pompare 35 °C.

Su richiesta possono essere fornite pompe con giranti e diffusori in acciaio inox.

 Submerged pumps suitable to pump clean water from deep wells and tanks for domestic and industrial uses, as well as for irrigation and sprinkling systems. High performance.

Discharge casing and motor coupling flange in brass. Impellers and diffusers in Noryl. Built-in check valve. Shaft and pump housing in stainless steel.

Water or oil bathed submerged motor with sand slinger. Three-phase voltage: the pump must be protected by a fused remote isolator switch. Protection class IP 58. Insulation class F.

Max. contents of sand 40 gr/m³. Max. temperature of pumped water 95 °F (35 °C).

On request it is possible to supply pumps with impellers and diffusers in stainless steel.

 Pompes de forage pour pomper l'eau propre de puits profonds et de bassins, pour la distribution d'eau dans les installations domestiques, pour les services industrielles, pour élever la pression du réseau hydrique et pour l'arrosage. Fonctionnement excellent.

Corps de refoulement et bride d'accouplement au moteur en laiton. Roues et diffuseurs en Noryl. Soupape de retenue incorporée. Arbre et chemise extérieure en acier inox.

Moteur lubrifié par eau ou par huile avec protection anti-sable. Bobinage triphasé avec protection par l'usager. Protection IP 58. Isolation classe F.

Contenu max. de sable 40 gr/m³. Température max. de l'eau pompée 35 °C.

Pompes avec roues et diffuseurs en acier inox sur demande.

 Unterwasserpumpen mit hoher Leistung zur Förderung von sauberem Wasser aus Tiefbrunnen. Verwendbar zur Hauswasserversorgung, für Springbrunnen, zur Bewässerung usw.

Auslaßgehäuse und Kupplungsflansch zum Motor aus Messing. Laufräder und Diffusoren aus Noryl. Rückschlagventil. Antriebswelle und Gehäusemantel aus rostfreiem Stahl.

Wasser-bzw. olgekühlter Tauchmotor mit Sandfilter. Dreiphasenspannung mit Motorvollschutz nach Benutzersorge. IP 58 Schutz. Isol. Klasse F.

Max. Sanddichte 40 Gr/m³. Max. Wassertemperatur 35 °C.

Auf Wunsch können diese Pumpen auch mit Laufräder und Diffusoren aus rostfreiem Stahl geliefert werden.

Modello Model Modèle Modell	Potenza Power Puissance Pferdestärke		Tensione Voltage Bobinage Spannung	A	Nr. stadi N. stages N. étages Stufenzahl	Prevalenza - Head - Hauteur - Förderhöhe (m)									
WELL R24						Portata - Capacity - Débit - Fördermenge (m³/h)									
	HP	kW	V-Hz-ph	A.	N.	0	3	6	9	12	15	18	21	24	
WELL R24-1250	12,5	9,2	400-50-3	21,5	17	204	200	193	182	166	148	122	89	50	
WELL R24-1500	15	11	400-50-3	23,7	21	252	251	240	232	213	186	158	118	70	
WELL R24-1750	17,5	13	400-50-3	27,8	24	290	287	274	260	235	209	174	127	75	
WELL R24-2000	20	15	400-50-3	30,4	28	336	326	315	290	271	238	199	150	87	
WELL R39						Portata - Capacity - Débit - Fördermenge (m³/h)									
	HP	kW	V-Hz-ph	A.	N.	0	5	10	15	20	25	30	35	39	
WELL R39-550	5,5	4	400-50-3	8,8	4	58	54	52	48	42	36	27	19	12	
WELL R39-1000	10	7,5	400-50-3	16,9	8	117	112	103	93	86	75	60	45	34	
WELL R39-1500	15	11	400-50-3	23,7	12	174	166	154	140	125	112	87	70	50	
WELL R39-2000	20	15	400-50-3	30,4	16	233	218	205	186	163	144	118	85	71	
WELL R39-2500	25	18,5	400-50-3	38,3	20	295	282	264	239	214	189	156	115	90	
WELL R39-3000	30	22	400-50-3	44,0	24	350	337	318	293	265	235	200	155	120	
WELL R48						Portata - Capacity - Débit - Fördermenge (m³/h)									
	HP	kW	V-Hz-ph	A.	N.	0	6	12	18	24	30	36	42	48	
WELL R48-550	5,5	4	400-50-3	8,8	3	47	45	43	42	35	33	30	23	13	
WELL R48-1000	10	7,5	400-50-3	16,9	5	75	73	71	68	63	57	48	36	22	
WELL R48-1500	15	11	400-50-3	23,7	8	123	120	118	109	101	92	76	60	35	
WELL R48-2500	25	18,5	400-50-3	38,3	12	180	175	165	158	140	127	115	80	53	
WELL R48-3000	30	22	400-50-3	44,0	15	225	223	218	204	191	171	144	110	67	
WELL R48-4000	40	30	400-50-3	62,0	20	300	298	287	272	252	228	190	145	87	
WELL R48-5000	50	37	400-50-3	72,0	24	357	352	341	324	303	273	226	175	104	

*On request other voltages are available

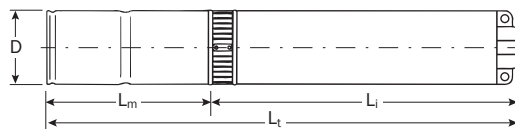
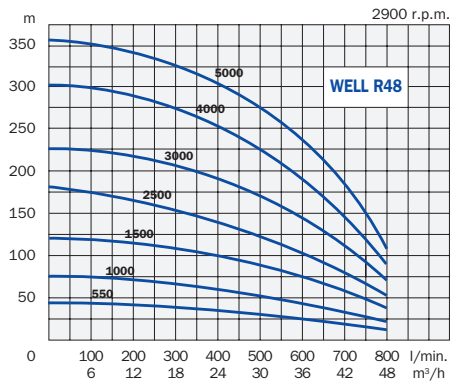
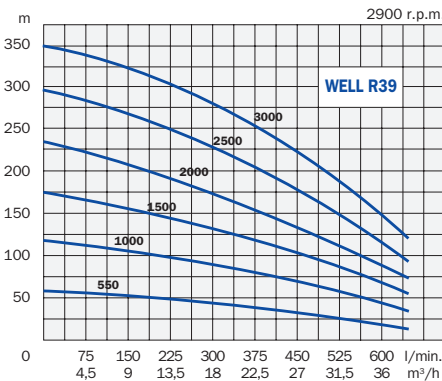
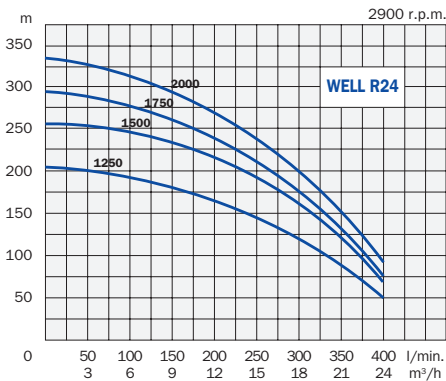

Modello Model Modèle Modell	Mandata Discharge Refoulement Druck-Seite	Dimension - Dimensions Masstabelle				Peso - Weight - Poids - Gewicht kg		
		D	L _m	L _i	L _t	Motor Motor Moteur Motor	Pompa Pump Pompe Pumpe	Totale Total Totale Total
WELL R24-1250	2"1/2 - DN 65	145 (6")	673	1270	1870	45	25	70
WELL R24-1500	2"1/2 - DN 65	145 (6")	773	1470	2170	48	28	76
WELL R24-1750	2"1/2 - DN 65	145 (6")	773	1620	2320	50	30	80
WELL R24-2000	2"1/2 - DN 65	145 (6")	833	1820	2580	54	33	87
WELL R39-550	2"1/2 - DN 65	145 (6")	613	650	1190	32	14	46
WELL R39-1000	2"1/2 - DN 65	145 (6")	673	880	1480	42	17	59
WELL R39-1500	2"1/2 - DN 65	145 (6")	773	1105	1805	48	20	68
WELL R39-2000	2"1/2 - DN 65	145 (6")	833	1335	2095	54	24	78
WELL R39-2500	2"1/2 - DN 65	145 (6")	903	1615	2445	65	27	92
WELL R39-3000	2"1/2 - DN 65	145 (6")	963	1840	2730	70	31	101
WELL R48-550	3" - DN 80	145 (6")	613	600	1140	32	13	45
WELL R48-1000	3" - DN 80	145 (6")	673	720	1320	42	16	58
WELL R48-1500	3" - DN 80	145 (6")	773	900	1600	48	18	66
WELL R48-2500	3" - DN 80	145 (6")	903	1145	1975	65	21	86
WELL R48-3000	3" - DN 80	145 (6")	963	1325	2215	70	23	93
WELL R48-4000	3" - DN 80	145 (6")	1103	1675	2705	90	28	118
WELL R48-5000	3" - DN 80	145 (6")	1243	1915	3085	101	32	133

POMPE AUTOADESCANTI

SELF-PRIMING PUMPS



JET N

JET INOX



 Pompe autoadescenti ideali per impianti domestici e per irrigazione di orti e giardini. Particolarmente indicate per autoclavi.

Alto rendimento. Aspirazione fino a 9 metri.

Corpo pompa in ghisa sui modelli JET 80 N – 100 N; in acciaio inox AISI 304 sui modelli JET 80 INOX – 100 INOX. Girante in noryl. Tenuta meccanica in ceramica/grafite. Motore chiuso autoventilato. Albero in acciaio inox. Tensione monofase con protezione termica incorporata.

Protezione IP 44. Isolamento classe F. Temperatura massima dell'acqua da pompare: 50 °C per la serie JET N, 35 °C per la serie JET INOX.

 Self-priming pumps suitable for the raising and the distribution of water in domestic plants and for small irrigation systems.

They are also recommended for pressure systems. High performance. Suction head up to 9 metres depth.

Pump body in cast iron on models JET 80 N – 100 N; in stainless steel AISI 304 on models JET 80 INOX – 100 INOX. Impeller in noryl. Mechanical seal in ceramic/carbon. Closed self-ventilated motor. Shaft in stainless steel.

Single-phase voltage with built-in motor protector.

Protection class IP 44. Insulation class F. Max. temperature of pumped water: 122 °F (50 °C) for series JET N, 95 °F (35 °C) for series JET INOX.

 Pompes autoamorçantes indiquées pour la distribution d'eau dans les installations domestiques et pour de petites irrigations.

Particulièrement indiquées pour groupes surpresseurs. Rendement élevé. Sécurité de fonctionnement. Aspiration jusqu'à 9 mètres de profondeur.

Corps de pompe en fonte sur les modèles JET 80 N – 100 N; en acier inox AISI 304 sur les modèles JET 80 INOX – 100 INOX. Roue en noryl. Garniture mécanique en céramique/graphite. Moteur enfermé avec ventilation extérieure. Arbre en acier inox.

Bobinage monophasé avec protection thermique incorporée. Protection IP 44. Isolation classe F. Température max. de l'eau pompée: 50 °C pour la série JET N, 35 °C pour la série JET INOX.

 Selbstansaugende Pumpen zur Hauswasserversorgung, zur Bewässerung usw. Hohe Förderleistung. Sicher im Betrieb. Manometrische Saughöhe: 9 Meter.

Pumpengehäuse aus Grauguß bei den Modellen JET 80 N – 100 N; aus rostfreiem Stahl AISI 304 bei den Modellen JET 80 INOX – 100 INOX. Laufrad aus Noryl. Keramik/Graphit Gleitringdichtung. Antriebswelle aus rostfreiem Stahl.

Einphasenspannung mit thermischen Motorschutz. IP 44 Schutz. Isol. Klasse F. Max. Temperatur der Flüssigkeit: 50 °C bei den Modellen JET N, 35 °C bei den Modellen JET INOX.

Modello Model Modèle Modell	Potenza Power Puissance Pferdestärke		Tensione Voltage Bobinage Spannung V-Hz-ph	A	Portata - Capacity - Débit - Fördermenge (l/min)							
	HP	kW			Prevalenza - Head - Hauteur - Förderhöhe (m)							
					0	10	20	30	40	50	60	
JET 80 N	0,8	0,59	230-50-1	2,9	40	35	29	21	12			
JET 100 N	1	0,75	230-50-1	4,7	48	45	41	36	29	21	11	
JET 80 INOX	0,8	0,59	230-50-1	3,8	42	37	29	21	10			
JET 100 INOX	1	0,75	230-50-1	4,8	51	45	37	28	19	7		

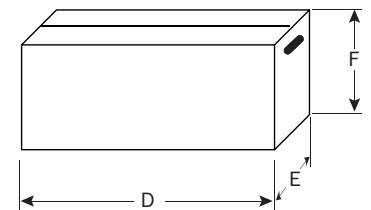
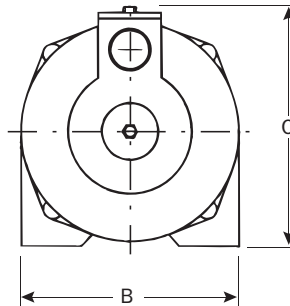
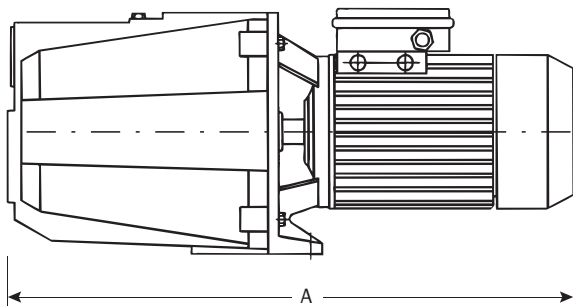
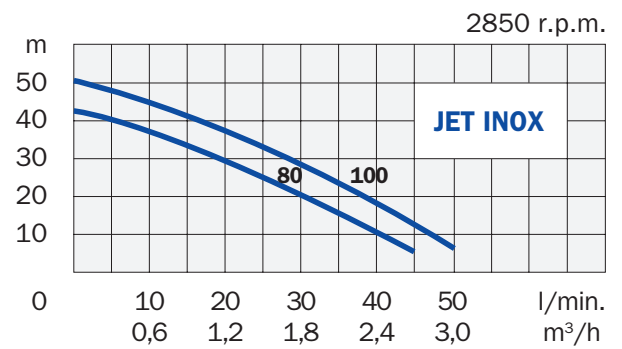
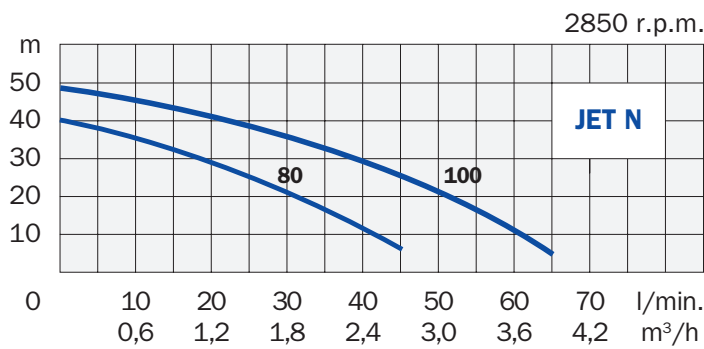

Modello Model Modèle Modell	Aspirazione Suction Aspiration Saug-Seite	Mandata Discharge Refoulement Druck-Seite	Dimensioni - Dimensions - Masstabelle						Peso Weight Poids Gewicht kg
			mm						
			A	B	C	D	E	F	
JET 80 N	1" - DN 25	1" - DN 25	366	190	210	410	200	220	10
JET 100 N	1" - DN 25	1" - DN 25	390	190	210	410	200	220	12
JET 80 INOX	1" - DN 25	1" - DN 25	366	200	220	375	210	250	7
JET 100 INOX	1" - DN 25	1" - DN 25	366	200	220	375	210	250	9

POMPE AUTOADESCANTI

SELF-PRIMING PUMPS

SUPERJET 100



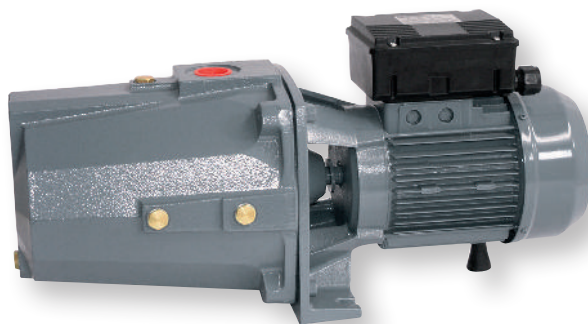

SUPERJET 150-300



-  Pompe autoadesanti ideali per impianti domestici e industriali, per lavaggi con getti e giardinaggio. Robusta costruzione. Alto rendimento. Portate elevate. Servizio continuo. Aspirazione fino a 9 metri. Corpo pompa e supporto in ghisa. Girante in ottone. Tenuta meccanica in ceramica/grafite. Motore chiuso autoventilato. Albero in acciaio inox AISI 416. Tensione monofase con protezione termica incorporata; tensione trifase con protezione a cura dell'utente. IP 44 sul modello SUPERJET 100, IP 55 sui modelli superiori. Isolamento classe F. Temperatura massima dell'acqua 50 °C.

-  Self-priming pumps suitable for domestic and industrial plants, for gardening, for washing with water jet. Heavy duty construction. High performance. High deliveries. Continuous service. Suction head up to 9 metres depth. Pump body and pump support in cast iron. Impeller in brass. Mechanical seal in ceramic/carbon. Closed self-ventilated motor. Shaft in stainless steel AISI 416. Single-phase voltage pumps with built-in motor protector. The three-phase voltage pumps must be protected by a fused remote isolator switch. IP 44 on model SUPERJET 100, IP 55 on other models. Insulation class F. Max. water temperature 122 °F (50 °C).

-  Pompes autoamorçantes indiquées pour la distribution d'eau dans les installations domestiques et industrielles, pour lavages à jet d'eau, pour arrosage, etc. Construction robuste. Rendement élevé. Débits élevés. Aspiration jusqu'à 9 mètres de profondeur. Corps de pompe et support en fonte. Roue en laiton. Garniture mécanique en céramique/graphite. Moteur enfermé avec ventilation extérieure. Arbre en acier inox AISI 416. Bobinage monophasé avec protection thermique incorporée; bobinage triphasé avec protection par l'utilisateur. IP 44 sur le modèle SUPERJET 100; IP 55 sur les autres modèles. Isolation classe F. Température max. de l'eau 50 °C.

-  Selbstansaugende Pumpen zur Hauswasserversorgung, zur Bewässerung usw. Die Pumpen sind aus hochwertigen Materialien hergestellt und haben eine sehr hohe Förderleistung. Manometrische Saughöhe bis zu 9 Meter. Pumpengehäuse aus Grauguß. Laufrad aus Messing. Keramik/Graphit Gleitringdichtung. Antriebswelle aus rostfreiem Stahl AISI 416. Einphasenspannung mit thermischen Motorschutz; Dreiphasenspannung mit Motorvollschutz nach Benutzersorge. IP 44 Schutz beim Modell SUPERJET 100, IP 55 Schutz bei allen anderen Modellen. Isol. Klasse F. Max Temperatur der Flüssigkeit: 50 °C.

Modello Model Modèle Modell	Potenza Power Puissance Pferdestärke		Tensione Voltage Bobinaje Spannung V-Hz-ph	A	Portata - Capacity - Débit - Fördermenge (l/min)									
	HP	kW			0	20	40	60	80	100	120	140		
	Prevalenza - Head - Hauteur - Förderhöhe (m)													
SUPERJET 100	1	0,75	230-50-1	4,5	43	36	24	3						
SUPERJET 150	1,5	1,1	230-50-1	8,5	50	46	40	35	28	20	11			
			230/400-50-3	8,0/4,6										
SUPERJET 200	2	1,5	230-50-1	9,4	56	52	47	42	35	28	19			
			230/400-50-3	8,5/4,9										
SUPERJET 300	3	2,2	230-50-1	11,9	62	57	53	48	42	35	26	15		
			230/400-50-3	8,7/5,0										

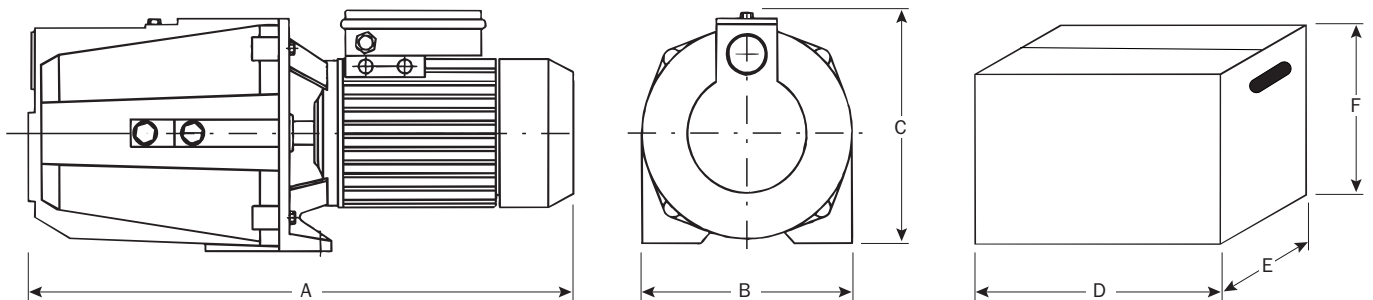
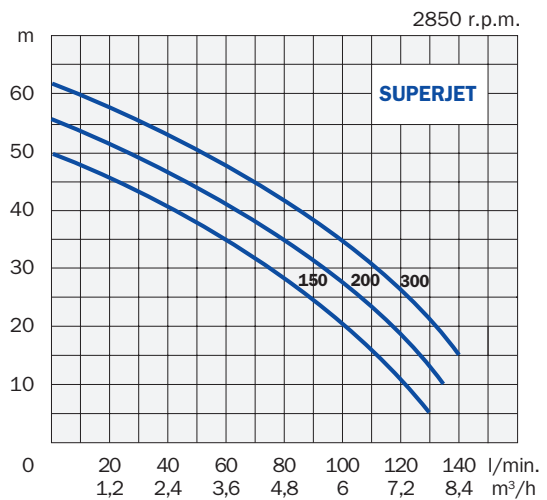
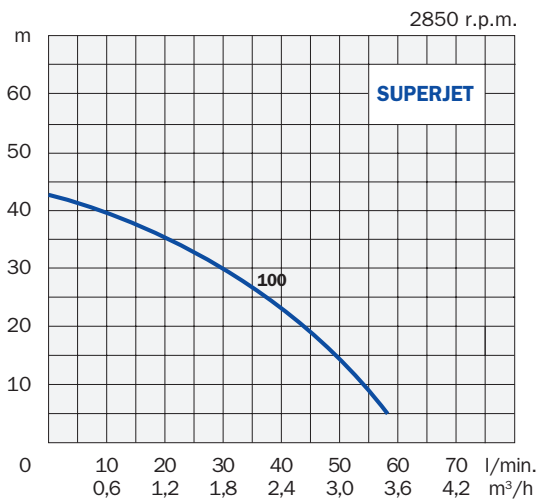

Modello Model Modèle Modell	Aspirazione Suction Aspiration Saug-Seite	Mandata Discharge Refoulement Druck-Seite	Dimensioni - Dimensions - Masstabelle						Peso Weight Poids Gewicht
			mm						
			A	B	C	D	E	F	
SUPERJET 100	1" - DN 25	1" - DN 25	425	185	200	440	220	240	17
SUPERJET 150	1"1/2 - DN 40	1"1/4 - DN 32	555	221	242	600	260	275	32
SUPERJET 200	1"1/2 - DN 40	1"1/4 - DN 32	555	221	242	600	260	275	33
SUPERJET 300	1"1/2 - DN 40	1"1/4 - DN 32	555	221	242	600	260	275	34

POMPE PERIFERICHE

PERIPHERAL PUMPS

P 50-80

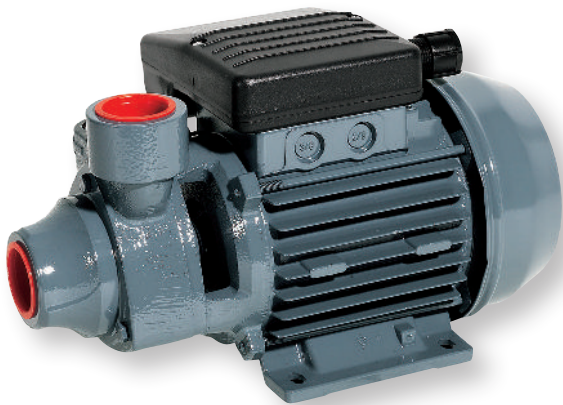

P 50 BRASS

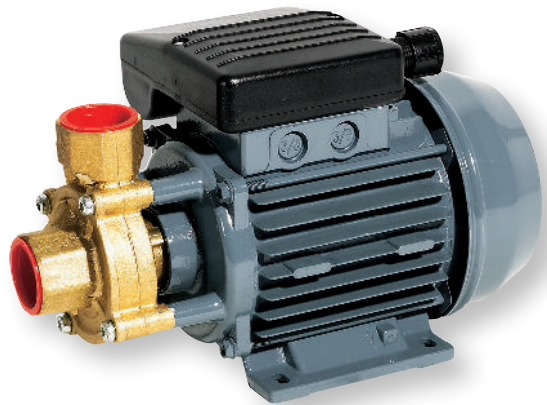

 Pompe periferiche particolarmente adatte per impianti domestici, per piccole irrigazioni, per usi industriali, ecc. Aspirazione fino a 3 metri.

Corpo pompa in ghisa o in ottone. Su richiesta sono disponibili anche con corpo in acciaio AISI 316. Girante in ottone ad alette radiali. Tenuta meccanica in ceramica/grafite. Motore chiuso autoventilato. Albero in acciaio inox.

Protezione IP 44. Isolamento classe F. Temperatura massima dell'acqua da pompare 50 °C. Il modello P 50 BRASS, è particolarmente utilizzato nell'industria lattiero-casearia per il lavaggio degli impianti di produzione con detergenti.

Il modello P50 BRASS è disponibile anche con tenuta meccanica in VITON per pompare acqua calda fino a 80 °C.

 Peripheral pumps suitable for domestic plants, for small irrigation systems, for industrial uses, etc. Suction head up to 3 metres depth.

Pump body in cast iron or in brass. On request the pumps are available also with pump body in stainless steel AISI 316. Impeller in brass with radial blades. Mechanical seal in ceramic/carbon. Closed self-ventilated motor. Shaft in stainless steel.

Protection class IP 44. Insulation class F. Max. temperature of pumped water 122 °F (50 °C). The model P 50 BRASS is mainly uses in the dairy industry for the production plants cleansing with detergents.

Model P50 BRASS is available also with mechanical seal in VITON for hot water up to 176 °F (80 °C).

 Pompes périphériques pour la distribution d'eau dans les installations domestiques, pour arrosage de jardins, etc. Aspiration jusqu'à 3 mètres de profondeur

Corps de pompe en fonte ou en laiton. A la demande les pompes sont disponibles aussi avec le corps en acier inox AISI 316. Roue en laiton avec ailettes radiales. Garniture mécanique en céramique/graphite. Moteur enfermé avec ventilation extérieure. Arbre en acier inox.

Protection IP 44. Isolation classe F. Température max. de l'eau pompée 50 °C. Le modèle P 50 BRASS est particulièrement employé dans l'industrie laitier-fromager pour le lavage des machines.

Le modèle P50 BRASS est disponible aussi avec garniture mécanique en VITON pour eau chaude jusqu'à 80 °C.

 Wirbelpumpen mit Peripheralrad. Geeignet zur Hauswasserversorgung, zum industriellen Einsatz usw., sowohl im Dauerbetrieb, als auch im intermittierenden Betrieb. Manometrische Saughöhe bis zu 3 Meter.

Pumpengehäuse aus Grauguß oder Messing. Auf Wunsch Pumpengehäuse aus rostfreiem Stahl AISI 316 lieferbar. Laufrad aus Messing. Gleitringdichtung aus Keramik/Graphit. Antriebswelle aus rostfreiem Stahl.

IP 44 Schutz. Isol. Klasse F. Max. Temperatur der Flüssigkeit: 50 °C. Das Modell P 50 BRASS ist für die Wäsche von Betriebsanlagen des Molkereien empfohlen.

Auf Wunsch ist auch das Modell P50 BRASS mit Gleitringdichtung aus VITON für Heisswasser bis 80 °C lieferbar.

Modello Model Modèle Modell	Potenza Power Puissance Pferdestärke		Tensione Voltage Bobinage Spannung V-Hz-ph	A	Portata - Capacity - Débit - Fördermenge (l/min)							
	HP	kW			0	8	16	24	32	40	48	
	Prevalenza - Head - Hauteur - Förderhöhe (m)											
P 50	0,5	0,37	230-50-1	2,7	30	24	17	10	3			
P 50 BRASS	0,5	0,37	230-50-1	2,7	30	24	17	10	3			
P 80	0,8	0,59	230-50-1	5,2	55	48	39	30	22	14	6	

*On request other voltages are available

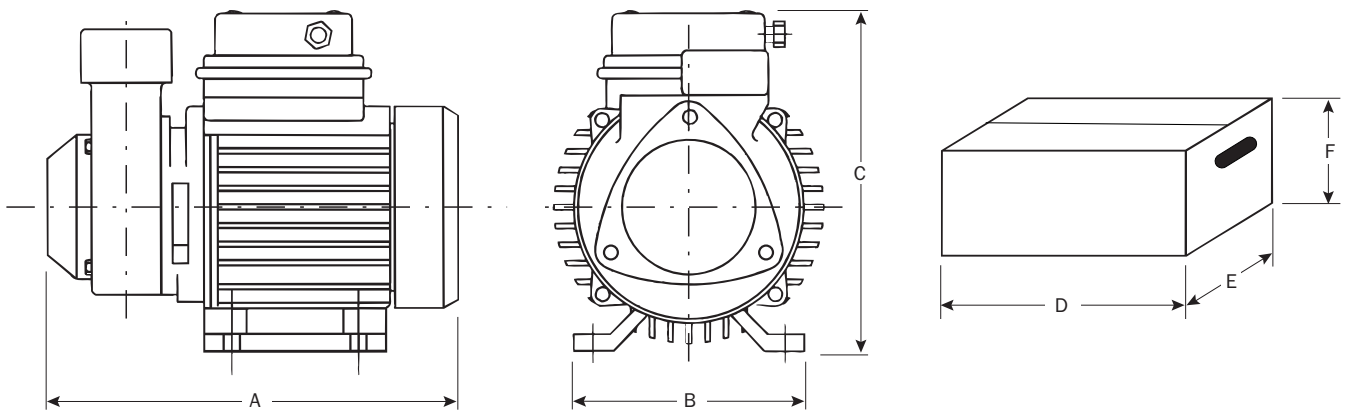
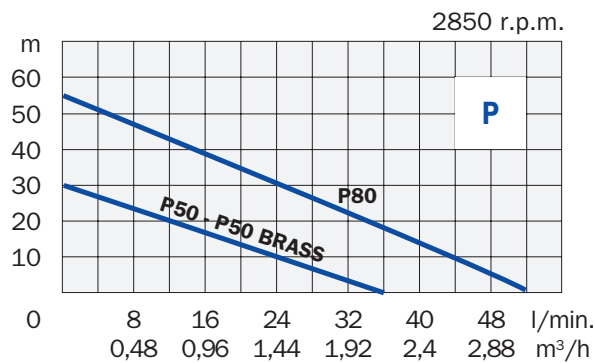



Modello Model Modèle Modell	Aspirazione Suction Aspiration Saug-Seite	Mandata Discharge Refoulement Druck-Seite	Dimensioni - Dimensions - Masstabelle						Peso Weight Poids Gewicht kg
			mm						
			A	B	C	D	E	F	
P 50	1" - DN 25	1" - DN 25	255	120	144	285	170	170	6,5
P 50 BRASS	1" - DN 25	1" - DN 25	250	145	160	290	180	200	5
P 80	1" - DN 25	1" - DN 25	295	160	175	310	175	215	9,2

POMPE CENTRIFUGHE MONOGIRANTI

SINGLE-STAGE CENTRIFUGAL PUMPS

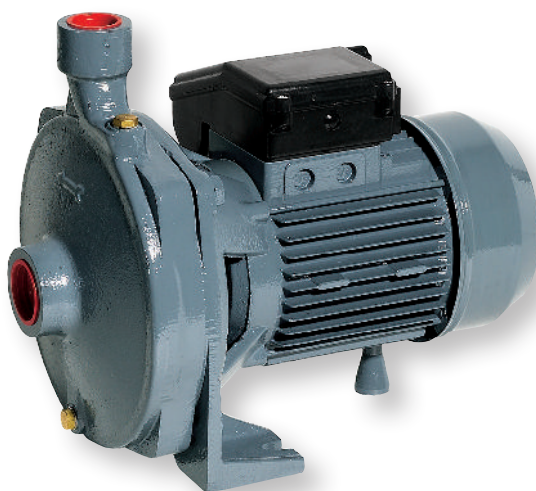
SERIE C



 Pompe centrifughe per la distribuzione d'acqua negli impianti domestici e per le piccole irrigazioni. Aspirazione fino a 3 metri.

Corpo pompa in ghisa. Girante in noryl nei modelli fino a 1 HP; in ottone per potenze superiori. Tenuta meccanica in ceramica/grafite. Motore chiuso autoventilato. Albero in acciaio inox AISI 416.

Tensione monofase con protezione termica incorporata; tensione trifase con protezione a cura dell'utente.

Protezione IP 44. Isolamento classe F. Temperatura massima dell'acqua da pompare 50 °C per i modelli fino ad 1HP; 70 °C per i modelli superiori.

 Centrifugal pumps suitable for the raising and the distribution of water in domestic plants and for a lot of jobs around the house and farm. Suction head up to 3 metres depth.

Pump body in cast iron. Impeller in noryl on models up to 0.75kW; in brass on other models. Mechanical seal in ceramic/carbon. Closed self-ventilated motor. Shaft in stainless steel AISI 416.

Single-phase voltage with built-in motor protector. The three-phase pump must be protected by a fused remote isolator switch.

Protection class IP 44. Insulation class F. Max. temperature of pumped water 122 °F (50 °C) for models up to 0.75kW, 158 °F (70 °C) for bigger models.

 Pompes centrifuges indiquées pour la distribution d'eau dans les installations domestiques et pour plusieurs d'autres emplois autour des maisons, chalets et fermes. Aspiration jusqu'à 3 mètres de profondeur.

Corps de pompe en fonte. Roue en noryl sur les modèles jusqu'à 1 CV; en laiton sur les autres modèles. Garniture mécanique en céramique/graphite. Moteur enfermé avec ventilation extérieure. Arbre en acier inox AISI 416.

Bobinage monophasé avec protection thermique incorporée; bobinage triphasé avec protection par l'utilisateur.

Protection IP 44. Isolation classe F. Température max. de l'eau pompée 50 °C dans les modèles jusqu'à 1CV, 70 °C dans les autres modèles.

 Kreiselpumpen zur Hauswasserversorgung und für Bewässerungsanlagen. Manometrische Saughöhe bis zu 3 Meter.

Pumpengehäuse aus Grauguß. Laufrad aus Noryl bei Pumpen bis zu einer Leistung von 1 HP; aus Messing bei Pumpen mit höherer Leistung. Keramik/Graphit Gleitringdichtung. Antriebswelle aus rostfreiem Stahl AISI 416.

Einphasenspannung mit thermischen Motorschutz; Dreiphasenspannung mit Motorvollschutz nach Benutzersorge.

IP 44 Schutz. Isol. Klasse F. Max. Temperatur der Flüssigkeit: 50 °C bei den Modellen bis zu 1HP, 70 °C bei allen anderen Modellen.

Modello Model Modèle Modell	Potenza Power Puissance Pferdestärke		Tensione Voltage Bobinaje Spannung V-Hz-ph	A	Portata - Capacity - Débit - Fördermenge (l/min)											
	HP	kW			Prevalenza - Head - Hauteur - Förderhöhe (m)											
					0	20	40	80	120	160	200	240	280			
C 50	0,5	0,37	230-50-1	3,0	24	22	20	10								
			230/400-50-3	1,8/1,0												
C 75	0,75	0,55	230-50-1	4,5	29	27	25	16								
			230/400-50-3	2,6/1,5												
C 100	1	0,75	230-50-1	5,2	32	31	29	22								
			230/400-50-3	3,2/1,8												
C 150	1,5	1,1	230-50-1	8,9	40	39	37	33	27							
			230/400-50-3	4,8/3,0												
C 200	2	1,5	230-50-1	11,9	48	47	45	42	35							
			230/400-50-3	6,4/3,8												
C 300	3	2,2	230/400-50-3	9,2/5,2	55	54	51	46	40							
C 400	4	3	230/400-50-3	14,0/8,0	47	46	46	45	44	43	41	39	35			
C 550	5,5	4	230/400-50-3	17,0/10,0	57	56	56	56	55	54	53	50	48			

*On request other voltages are available

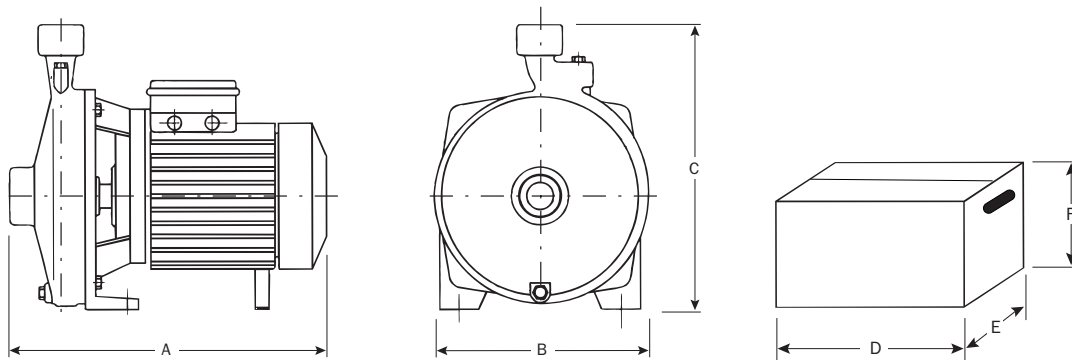
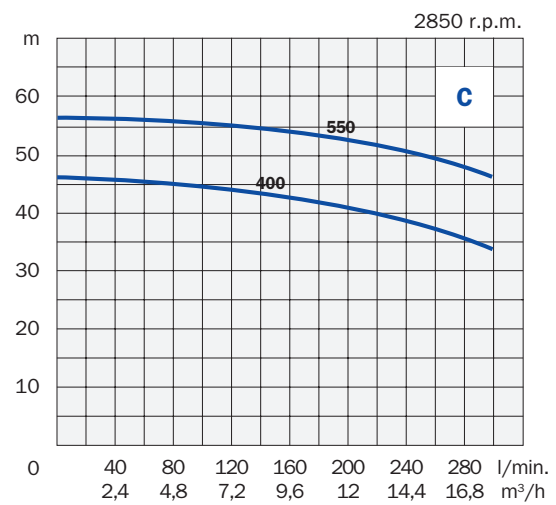
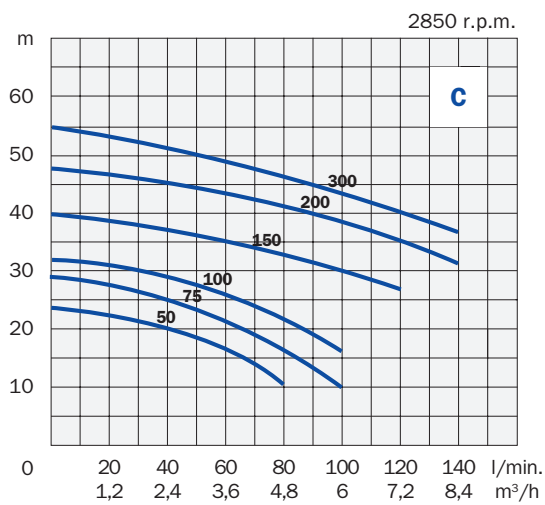



Modello Model Modèle Modell	Aspirazione Suction Aspiration Saug-Seite	Mandata Discharge Refoulement Druck-Seite	Dimensioni - Dimensions - Masstabelle						Peso Weight Poids Gewicht
			mm						
			A	B	C	D	E	F	
C 50	1" - DN 25	1" - DN 25	265	175	230	290	190	250	9
C 75	1" - DN 25	1" - DN 25	315	180	250	320	210	270	13
C 100	1" - DN 25	1" - DN 25	315	180	250	320	210	270	14
C 150	1"1/4 - DN 32	1" - DN 25	360	230	300	385	235	320	20
C 200	1"1/4 - DN 32	1" - DN 25	360	230	300	385	235	320	24
C 300	1"1/4 - DN 32	1" - DN 25	360	230	300	385	235	320	25
C 400	2" - DN 50	1"1/4 - DN 32	450	250	320	470	285	355	36
C 550	2" - DN 50	1"1/4 - DN 32	450	250	320	470	285	355	38

POMPE CENTRIFUGHE BIGIRANTI

TWO-STAGES CENTRIFUGAL PUMPS

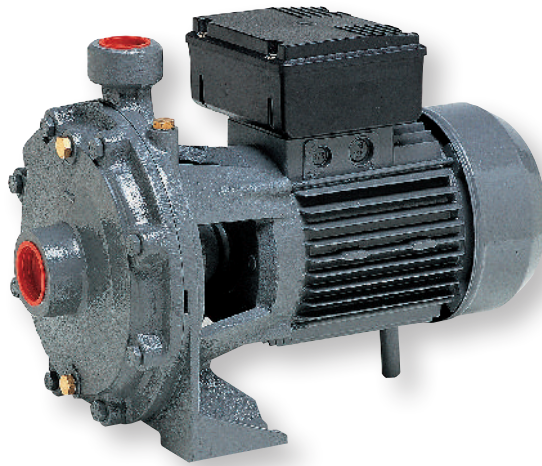
SERIE 2C



 Pompe bigiranti particolarmente adatte per la distribuzione d'acqua negli impianti domestici. Si prestano bene anche alla distribuzione d'acqua a mezzo di gruppi di pressurizzazione. Robusta costruzione. Alto rendimento. Aspirazione fino a 3 metri. Corpo pompa in ghisa. Giranti in ottone. Tenuta meccanica in ceramica/grafite. Motore chiuso autoventilato. Albero in acciaio inox AISI 304.

Tensione monofase con protezione termica incorporata; tensione trifase con protezione a cura dell'utente.
Protezione IP 44. Isolamento classe F. Temperatura massima dell'acqua da pompare 70 °C.

 Two-stages pumps suitable for the raising and the distribution of water in houses, hotels and farms. They are also suitable for the distribution of water by means of pressure systems. Heavy duty construction. High performance. Suction head up to 3 metres depth.

Pump body in cast iron. Impellers in brass. Mechanical seal in ceramic/carbon. Closed self-ventilated motor. Shaft in stainless steel AISI 304.

Single-phase voltage with built-in motor protector. The three-phase pumps must be protected by a fused remote isolator switch.
Protection class IP 44. Insulation class F. Max. temperature of pumped water 158 °F (70 °C).

 Pompes à deux roues indiquées pour la distribution d'eau dans les installations domestiques. Elles sont conseillées aussi pour la distribution automatique d'eau au moyen de groupes hydrophores. Construction robuste. Rendement élevé. Aspiration jusqu'à 3 mètres de profondeur.

Corps de pompe en fonte. Roues en laiton. Garniture mécanique en céramique/graphite. Moteur enfermé avec ventilation extérieure. Arbre en acier inox AISI 304.

Bobinage monophasé avec protection thermique incorporée; bobinage triphasé avec protection par l'utilisateur.
Protection IP 44. Isolation classe F. Température max. de l'eau pompée 70 °C.

 Zweirad-Pumpen zur Haushaltenanlagen und zur Bewässerungen von Gemüse- und Ziegärten. Höchste Leistungskraft. Sicher im Betrieb. Hergestellt aus hochwertigen Rohstoffen. Manometrische Saughöhe bis zu 3 Meter.

Pumpengehäuse aus Grauguß. Laufräder aus Messing. Keramik/Graphit Gleitringdichtung. Antriebswelle aus rostfreiem Stahl AISI 304.

Einphasenspannung mit thermischen Motorschutz; Dreiphasenspannung mit Motorvollschutz nach Benutzersorge.
IP 44 Schutz. Isol. Klasse F. Max. Temperatur der Flüssigkeit: 70 °C.

Modello Model Modèle Modell	Potenza Power Puissance Pferdestärke		Tensione Voltage Bobinage Spannung	A	Portata - Capacity - Débit - Fördermenge (l/min)						
	HP	kW			0	30	60	90	120	150	180
			V-Hz-ph	Prevalenza - Head - Hauteur - Förderhöhe (m)							
2C 100	1	0,75	230-50-1	5,2	42	35	26				
			230/400-50-3	3,2/1,8							
2C 150	1,5	1,1	230-50-1	8,0	51	47	40	30			
			230/400-50-3	4,8/3,0							
2C 200	2	1,5	230-50-1	11,5	60	57	52	43			
			230/400-50-3	6,4/3,8							
2C 300	3	2,2	230/400-50-3	9,2/5,2	67	64	60	54	44		
2C 400	4	3	230/400-50-3	14,0/8,0	72	71	68	63	55	45	
2C 550	5,5	4	230/400-50-3	17,0/10,0	81	79	76	72	65	55	
2C 750	7,5	5,5	230/400-50-3	20,0/11,5	90	88	85	80	73	64 50	

*On request other voltages are available

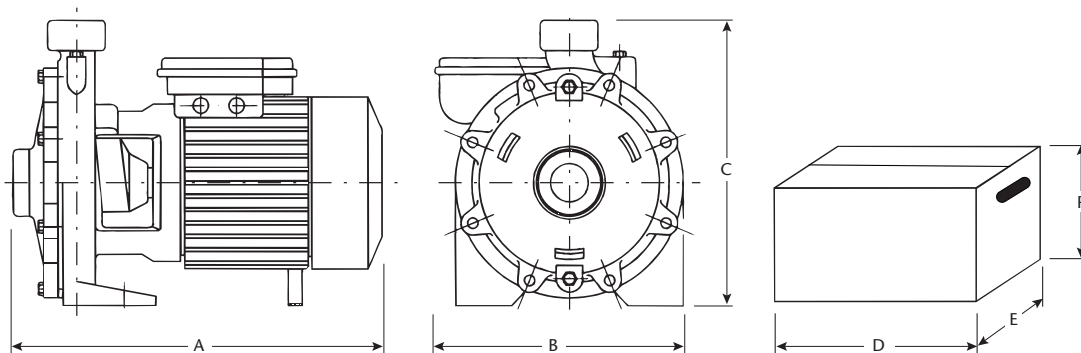
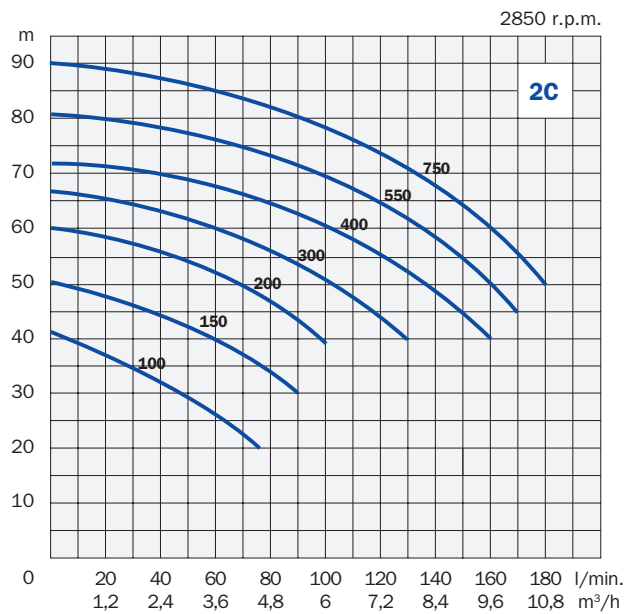



Modello Model Modèle Modell	Aspirazione Suction Aspiration Saug-Seite	Mandata Discharge Refoulement Druck-Seite	Dimensioni - Dimensions - Masstabelle						Peso Weight Poids Gewicht
			mm						
			A	B	C	D	E	F	
2C 100	1"1/4 - DN 32	1" - DN 25	344	190	234	370	200	260	16
2C 150	1"1/4 - DN 32	1" - DN 25	376	224	270	390	240	300	24
2C 200	1"1/4 - DN 32	1" - DN 25	376	224	270	390	240	300	25
2C 300	1"1/4 - DN 32	1" - DN 25	376	224	270	390	240	300	26
2C 400	1"1/2 - DN 40	1"1/4 - DN 32	462	265	306	550	300	360	42
2C 550	1"1/2 - DN 40	1"1/4 - DN 32	462	265	306	550	300	360	45
2C 750	1"1/2 - DN 40	1"1/4 - DN 32	462	265	306	550	300	360	46

POMPE CENTRIFUGHE MONOBLOCCO

CLOSE COUPLED CENTRIFUGAL PUMPS

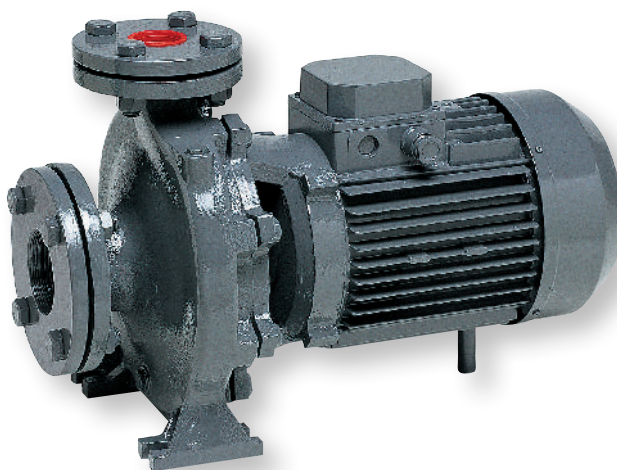
SERIE CF



 Pompe centrifughe monoblocco che trovano impiego in campo civile, agricolo e industriale: alimentazione di autoclavi, impianti di condizionamento, irrigazioni, ecc. Sono adatte al pompaggio di acqua pulita. Massima profondità di aspirazione consigliata: 1 metro.

Corpo pompa in ghisa. Girante in ottone nei modelli fino a 5,5 HP; girante in ghisa sugli altri modelli. Tenuta meccanica in ceramica/grafite. Motore chiuso autoventilato. Albero in acciaio inox AISI 304.

Tensione trifase 230/400V sui modelli fino a 5,5 HP; tensione trifase 400/690V per potenze superiori. Protezione a cura dell'utente.

Protezione IP 55. Isolamento classe F. Temperatura massima dell'acqua da pompare 70 °C.

 Close coupled single-stage centrifugal pumps suitable for pumping clean water. They are used in civil, industrial and agricultural plants: water supply, irrigations, feeding of steam boilers, heating and conditioning plants, etc. Maximum suggested suction head: 1 metre.

Pump body in cast iron. Impeller in brass on models up to 4,0 kW; in cast iron on other models. Mechanical seal in ceramic/carbon. Closed self-ventilated motor. Shaft in stainless steel AISI 304.

Three-phase voltage 230/400V on models up to 4,0 kW; three-phase voltage 400/690V on other models. The three-phase pumps must be protected by a fused remote isolator switch.

Protection class IP 55. Insulation class F. Max. temperature of pumped water 158 °F (70 °C).

 Pompes centrifuges monobloc indiquées pour plusieurs emplois dans les installations domestiques, industrielles et agricoles: approvisionnement d'eau, irrigations, groupes surpresseurs, conditionnement thermique, etc.

Elles sont indiquées pour le pompage d'eau propre. Profondeur maximum d'aspiration recommandée: 1 mètre.

Corps de pompe en fonte. Roue en laiton sur les modèles jusqu'à 5,5 CV; roue en fonte sur les autres modèles. Garniture mécanique en céramique/graphite. Moteur enfermé avec ventilation extérieure. Arbre en acier inox AISI 304.

Bobinage triphasé 230/400V sur les modèles jusqu'à 5,5 CV; bobinage triphasé 400/690V sur les autres modèles. Protection par l'utilisateur.

Protection IP 55. Isolation classe F. Température max. de l'eau pompée 70 °C.

 Kreiselpumpen in Blockbauweise.

Ideal für verschiedene Anforderungen im Haushalt, in der Landwirtschaft oder in der Industrie zur Wasserversorgung, zur Bewässerung usw. Diese Pumpen sind nur für sauberes Wasser geeignet. Empfohlene maximale Saughöhe: 1 Meter

Pumpengehäuse aus Grauguß. Laufrad aus Messing bei den Modellen bis zu 4 kW; Laufrad aus Grauguß bei allen anderen Modellen. Gleitringdichtung aus Keramik/Graphit. Antriebswelle aus rostfreiem Stahl.

Dreiphasenspannung 230/400V bei den Modellen bis zu 4 kW; Dreiphasenspannung 400/690V bei allen anderen Modellen. Motorvollschutz nach Benutzersorge.

IP 55 Schutz. Isol. Klasse F. Max. Temperatur der Flüssigkeit: 70 °C.

Modello Model Modèle Modell	Potenza Power Puissance Pferdestärke		Tensione Voltage Bobinage Spannung	A	Prevalenza - Head - Hauteur - Förderhöhe (m)							
	HP	kW			V-Hz-ph	A.	Portata - Capacity - Débit - Fördermenge (m ³ /h)					
CF 32	HP	kW	V-Hz-ph	A.	0	6	9	12	18	24	30	36
CF 32-160 400	4	3	230/400-50-3	11,6/6,8	48	45	42	39				
CF 32-160 550	5.5	4	230/400-50-3	16,0/9,2	58	57	55	52	45			
CF 32-200 1000	10	7.5	400/690-50-3	16,0/9,5	62	61	60	58	57	53	48	40
CF 40	HP	kW	V-Hz-ph	A.	0	6	12	18	24	30	36	42
CF 40-200 750	7.5	5.5	400/690-50-3	13,0/7,5	50	49	49	47	43	37	30	
CF 40-200 1000	10	7.5	400/690-50-3	16,0/9,5	61	60	59	57	53	48	40	
CF 40-250 1500	15	11	400/690-50-3	25,0/14,4	79	78	77	73	70	66	60	52
CF 40-250 2000	20	15	400/690-50-3	32,0/18,5	92	91	91	90	87	83	79	72
CF 50	HP	kW	V-Hz-ph	A.	0	18	27	36	45	54	63	72
CF 50-160 750	7.5	5.5	400/690-50-3	14,0/8,0	33	32	31	29	28	25	23	19
CF 50-200 1250	12.5	9.5	400/690-50-3	18,0/10,4	48		46	44	41	38	34	27
CF 50-200 2000	20	15	400/690-50-3	28,0/16,2	58		57	56	53	50	46	40
CF 50-250 2500	25	18.5	400/690-50-3	41,5/24,0	80		79	76	73	71	68	63
CF 50-250 3000	30	22	400/690-50-3	49,0/28,0	92		91	90	87	85	81	77
CF 65	HP	kW	V-Hz-ph	A.	0	45	60	75	90	105	120	135
CF 65-160 1250	12.5	9.5	400/690-50-3	19,5/11,5	32	31	29	28	26	23	21	17
CF 65-160 2000	20	15	400/690-50-3	27,0/15,6	41	40	40	39	38	37	35	32
CF 65-200 2500	25	18.5	400/690-50-3	39,0/22,5	51	50	50	49	48	47	44	42
CF 65-200 3000	30	22	400/690-50-3	45,0/26,0	59	58	58	57	55	53	52	48
CF 65-250 4000	40	30	400/690-50-3	63,5/35,0	74	73	73	72	71	69	65	61
CF 65-250 5000	50	37	400/690-50-3	74,5/44,0	91	90	90	89	88	85	81	74
CF 80	HP	kW	V-Hz-ph	A.	0	60	78	96	132	168	204	240
CF 80-160 1500	15	11	400/690-50-3	21,0/12,1	27	26	25	24	22	18		
CF 80-160 2000	20	15	400/690-50-3	26,0/15,0	32	31	29	28	25	21		
CF 80-160 2500	25	18.5	400/690-50-3	35,0/20,2	37	36	34	33	30	27	20	
CF 80-160 3000	30	22	400/690-50-3	41,0/23,7	41	40	39	38	35	32	24	
CF 80-200 4000	40	30	400/690-50-3	63,5/36,0	53			52	51	48	43	
CF 80-200 5000	50	37	400/690-50-3	74,5/44,0	62			61	59	57	53	47

*On request other voltages are available

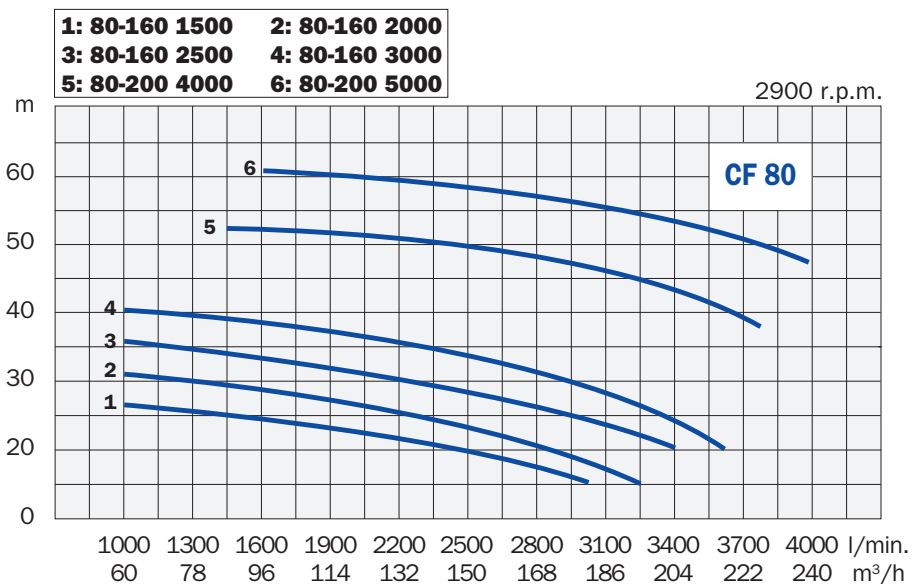
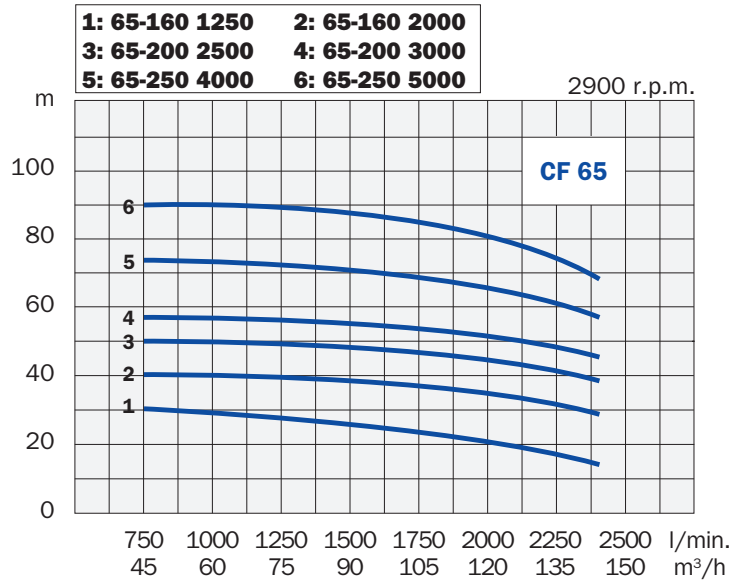
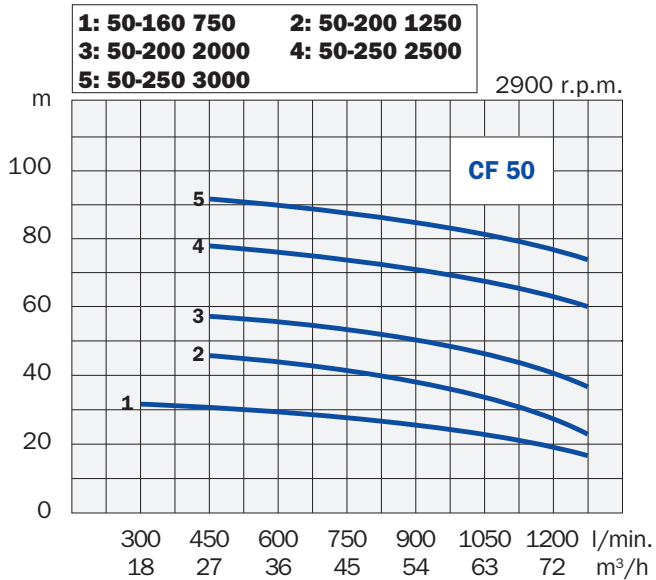
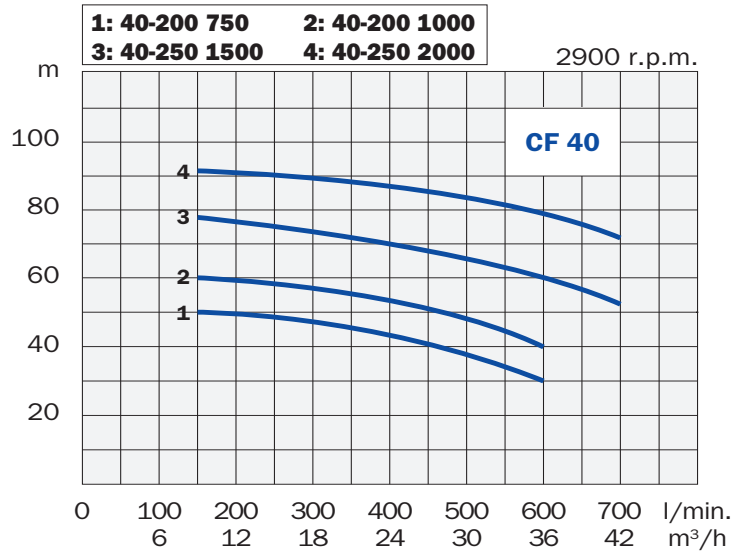
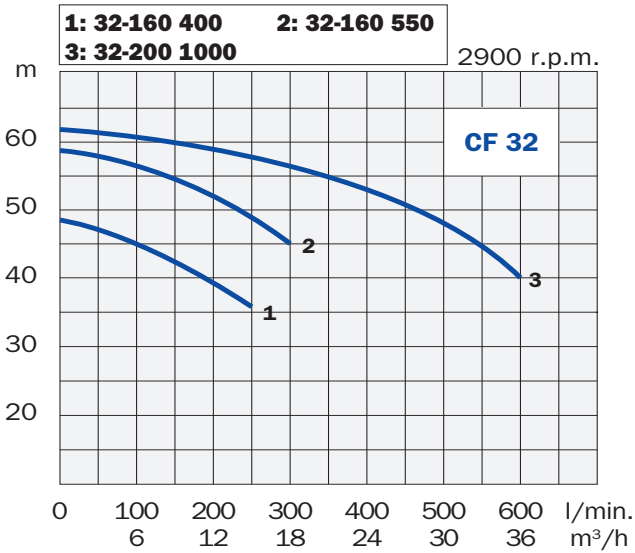

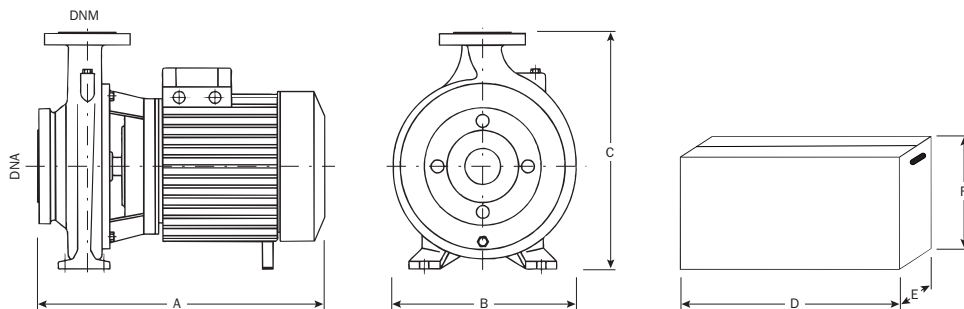

Modello Model Modèle Modell	Aspirazione Suction Aspiration Saug-Seite	Mandata Discharge Refoulement Druck-Seite	Dimensioni - Dimensions - Masstabelle mm						Peso Weight Poids Gewicht kg
			A	B	C	D	E	F	
CF 32									
CF 32-160 400	2" - DN50	1"1/4 - DN32	450	261	340	540	290	360	44
CF 32-160 550	2" - DN50	1"1/4 - DN32	450	261	340	540	290	360	46
CF 32-200 1000	2" - DN50	1"1/4 - DN32	541	268	340	660	350	600	72
CF 40									
CF 40-200 750	2"1/2 - DN65	1"1/2 - DN40	560	275	340	660	350	600	70
CF 40-200 1000	2"1/2 - DN65	1"1/2 - DN40	560	275	340	660	350	600	75
CF 40-250 1500	2"1/2 - DN65	1"1/2 - DN40	600	310	405	660	350	600	94
CF 40-250 2000	2"1/2 - DN65	1"1/2 - DN40	600	310	405	660	350	600	98
CF 50									
CF 50-160 750	2"1/2 - DN65	2" - DN50	560	256	340	660	350	530	68
CF 50-200 1250	2"1/2 - DN65	2" - DN50	565	287	360	660	350	530	83
CF 50-200 2000	2"1/2 - DN65	2" - DN50	605	287	360	660	350	530	95
CF 50-250 2500	2"1/2 - DN65	2" - DN50	725	332	405	810	360	530	135
CF 50-250 3000	2"1/2 - DN65	2" - DN50	725	332	405	810	360	530	145
CF 65									
CF 65-160 1250	3" - DN80	2"1/2 - DN65	565	269	360	660	350	530	82
CF 65-160 2000	3" - DN80	2"1/2 - DN65	565	269	360	660	350	530	97
CF 65-200 2500	3" - DN80	2"1/2 - DN65	725	330	405	810	360	530	135
CF 65-200 3000	3" - DN80	2"1/2 - DN65	725	330	405	810	360	530	145
CF 65-250 4000	3" - DN80	2"1/2 - DN65	776	360	455	820	400	600	239
CF 65-250 5000	3" - DN80	2"1/2 - DN65	788	360	455	820	400	600	253
CF 80									
CF 80-160 1500	4" - DN100	3" - DN80	635	328	405	660	350	530	97
CF 80-160 2000	4" - DN100	3" - DN80	635	328	405	660	350	530	117
CF 80-160 2500	4" - DN100	3" - DN80	755	330	405	810	360	530	140
CF 80-160 3000	4" - DN100	3" - DN80	755	330	405	810	360	530	150
CF 80-200 4000	4" - DN100	3" - DN80	840	355	405	850	380	530	233
CF 80-200 5000	4" - DN100	3" - DN80	840	355	405	850	380	530	247

POMPE CENTRIFUGHE MONOGIRANTI

SINGLE-STAGE CENTRIFUGAL PUMPS

SERIE CIR

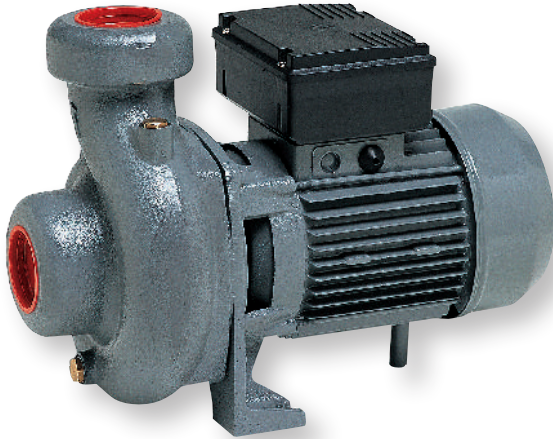

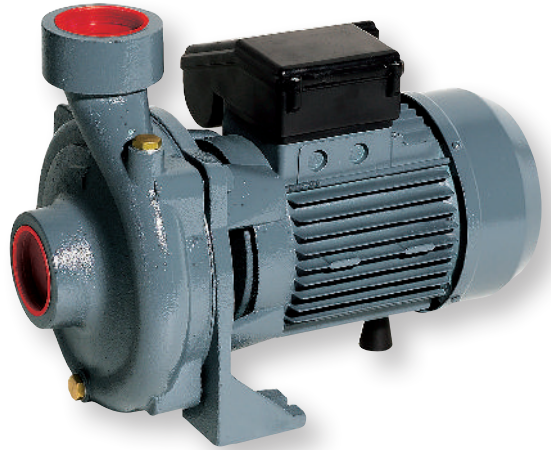

SERIE AGRI



-  Pompe centrifughe con grosse portate particolarmente indicate per l'irrigazione. Sicurezza di funzionamento e rendimento elevato. Massima profondità di aspirazione consigliata: 1 metro.
Corpo pompa in ghisa. Girante in ottone di tipo chiuso per la serie AGRI, di tipo aperto in ghisa per la serie CIR. Tenuta meccanica in ceramica/grafite. Motore chiuso autoventilato. Albero in acciaio inox.
Tensione monofase con protezione termica incorporata; tensione trifase con protezione a cura dell'utente.
Protezione IP 44. Isolamento classe F. Temperatura massima dell'acqua da pompare 40 °C.

-  Centrifugal pumps with large capacity suitable for irrigation systems. High performance. Maximum suggested suction head: 1 metre.
Pump body in cast iron. Closed type impeller in brass on the series AGRI, open type impeller in cast-iron on the series CIR.
Mechanical seal in ceramic/carbon. Closed self-ventilated motor. Shaft in stainless steel.
Single-phase voltage with built-in motor protector. The three-phase pumps must be protected by a fused remote isolator switch.
Protection class IP 44. Insulation class F. Max. temperature of pumped water 104 °F (40 °C).

-  Pompes centrifuges avec des gros débits indiquées pour installations industrielles et agricoles. Sécurité de fonctionnement et rendement élevé. Profondeur maximum d'aspiration recommandée: 1 mètre.
Corps de pompe en fonte. Roue en laiton de type fermé pour la série AGRI, roue en fonte de type ouvert pour la série CIR. Garniture mécanique en céramique/graphite. Moteur enfermé avec ventilation extérieure. Arbre en acier inox.
Bobinage monophasé avec protection thermique incorporée; bobinage triphasé avec protection par l'utilisateur.
Protection IP 44. Isolation classe F. Température max. de l'eau pompée 40 °C.

-  Kreiselpumpen mit grosser Fördermenge zur Hauswasserversorgung und für Bewässerungsanlagen.
Die Pumpen sind aus hochwertigen Materialien hergestellt und haben eine sehr hohe Förderleistung. Empfohlene maximale Saughöhe: 1 Meter.
Pumpengehäuse aus Grauguß. Geschlossenes Laufrad aus Messing bei Pumpen AGRI, offenes Laufrad aus Grauguß bei Pumpen CIR. Keramik/Graphit Gleitringdichtung. Antriebswelle aus rostfreiem Stahl.
Einphasenspannung mit thermischen Motorschutz; Dreiphasenspannung mit Motorvollschutz nach Benutzersorge.
IP 44 Schutz. Isol. Klasse F. Max. Temperatur der Flüssigkeit: 40 °C.

Modello Model Modèle Modell	Potenza Power Puissance Pferdestärke		Tensione Voltage Bobinage Spannung V-Hz-ph	A	Portata - Capacity - Débit - Fördermenge (l/min)							
	HP	kW			Prevalenza - Head - Hauteur - Förderhöhe (m)							
					50	200	400	600	800	1000	1200	1400
CIR 75	0,75	0,55	230-50-1	4,5	12	9						
			230/400-50-3	1,6/0,8								
CIR 100	1	0,75	230-50-1	5,0	14	11	4					
			230/400-50-3	2,2/1,3								
CIR 150	1,5	1,1	230-50-1	8,0	11	9	7					
			230/400-50-3	4,8/2,8								
CIR 200	2	1,5	230-50-1	10,0	13	11	9	7	4			
			230/400-50-3	6,7/3,8								
CIR 300	3	2,2	230/400-50-3	9,5/5,2	14	13	11	9	7			
CIR 550	5,5	4	230/400-50-3	14,0/9,0	18	17	16	14	13	11	8	
AGRI 150	1,5	1,1	230-50-1	9,4	20	16	8					
			230/400-50-3	5,4/3,1								
AGRI 200	2	1,5	230-50-1	11,7	28	23	14					
			230/400-50-3	7,3/4,0								
AGRI 300	3	2,2	230/400-50-3	9,0/5,3	33	29	21	5				

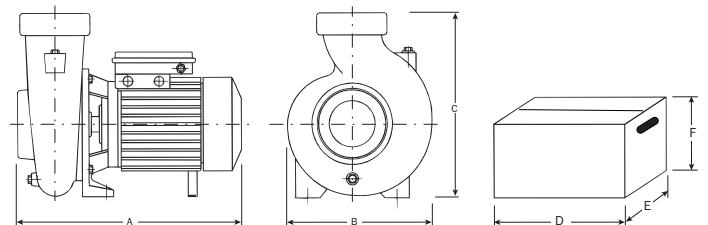
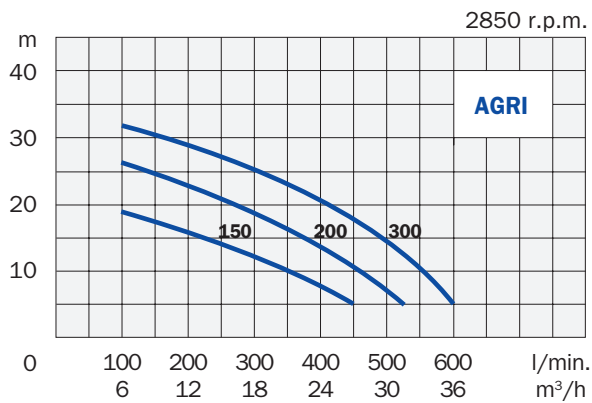
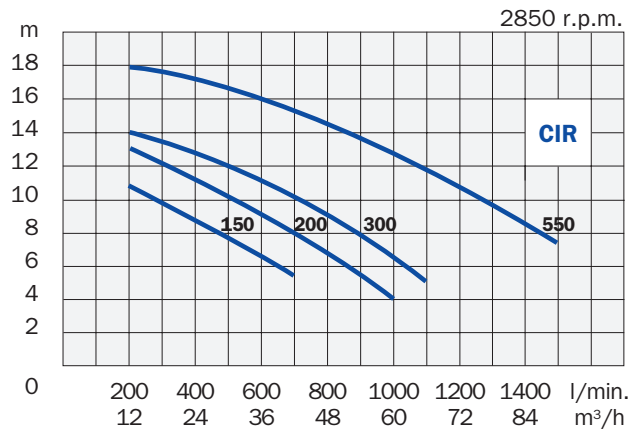
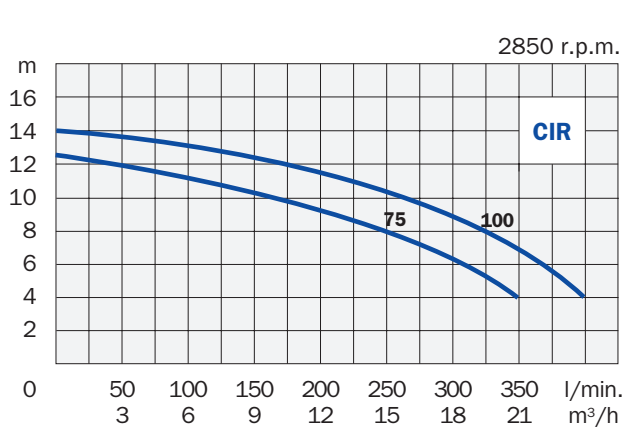

Modello Model Modèle Modell	Aspirazione Suction Aspiration Saug-Seite	Mandata Discharge Refoulement Druck-Seite	Dimensioni - Dimensions - Masstabelle						Peso Weight Poids Gewicht kg
			mm						
			A	B	C	D	E	F	
CIR 75	2" - DN 50	2" - DN 50	330	170	230	360	200	250	14
CIR 100	2" - DN 50	2" - DN 50	330	170	230	360	200	250	15
CIR 150	2" - DN 50	2" - DN 50	370	180	285	420	250	330	22
CIR 200	3" - DN 80	3" - DN 80	370	220	290	420	250	330	24
CIR 300	3" - DN 80	3" - DN 80	370	240	300	420	250	330	25
CIR 550	4" - DN 100	4" - DN 100	466	245	291	540	290	360	37
AGRI 150	2" - DN 50	2" - DN 50	370	210	280	400	240	340	24
AGRI 200	2" - DN 50	2" - DN 50	370	210	280	400	240	340	25
AGRI 300	2" - DN 50	2" - DN 50	370	210	280	400	240	340	26

POMPE MULTICELLULARI ORIZZONTALI

MULTISTAGE HORIZONTAL PUMPS

AUTODESCANTE
SELF-PRIMING

SERIE CM

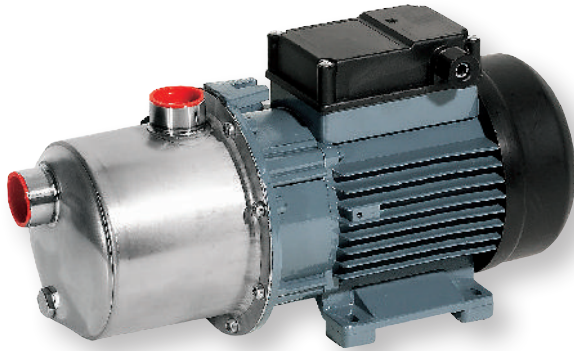

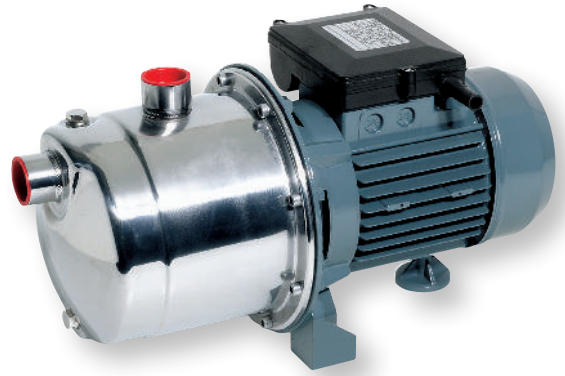

JET 5-120



- 
Pompe centrifughe multicellulari ideali per la pressurizzazione dell'acqua negli impianti domestici e per giardinaggio. Funzionamento molto silenzioso.
 Corpo pompa in acciaio inox. Tenuta meccanica in ceramica/grafite. Motore chiuso autoventilato. Albero in acciaio inox. Diffusori in noryl. I modelli della serie CM hanno giranti in acciaio inox ed aspirazione fino a 3 metri; il modello JET 5-120 ha giranti in noryl ed è **autoadescante fino ad 8 metri**.
 Tensione monofase con protezione termica incorporata. Il modello CM 200 è disponibile anche in tensione trifase 230/400V con protezione a cura dell'utente.
 Protezione IP 44. Isolamento classe F. Temperatura massima dell'acqua da pompare 40 °C.

- 
Multistage centrifugal pumps suitable for the raising and the distribution of water in domestic and commercial plants and for small irrigation systems. Quiet running.
 Pump body in stainless steel. Mechanical seal in ceramic/graphite. Closed self-ventilated motor. Shaft in stainless steel. Diffusers in noryl. The models of the series CM have impellers in stainless steel and suction head up to 3 metres depth; the model JET 5-120 has impellers in noryl and it is **self-priming with a suction head up to 8 metres**.
 Single-phase voltage with built-in motor protector. The model CM 200 is available also in three-phase voltage 230/400V and it must be protected by a fused remote isolator switch.
 Protection class IP 44. Insulation class F. Max. temperature of pumped water 104 °F (40 °C).

- 
Pompes centrifuges multicellulaires indiquées pour la distribution d'eau dans les installations domestiques et commerciales et pour de petites irrigations. Fonctionnement très silencieux.
 Corps de pompe en acier inox. Garniture mécanique en céramique/graphite. Moteur enfermé avec ventilation extérieure. Arbre en acier inox. Diffuseurs en noryl. Les modèles série CM ont les roues en acier inox et aspiration jusqu'à 3 mètres de profondeur; le modèle JET 5-120 a les roues en noryl et il est **autoamorçant avec aspiration jusqu'à 8 mètres de profondeur**.
 Bobinage monophasé avec protection thermique incorporée. Le modèle CM 200 est disponible aussi avec bobinage triphasé 230/400V avec protection par l'utilisateur.
 Protection IP 44. Isolation classe F. Température max. de l'eau pompée 40 °C.

- 
Mehrstufige Kreiselpumpen zur Hauswasser versorgung, zur Bewässerung usw. Geräuschloser Betrieb.
 Pumpengehäuse aus rostfreiem Stahl. Gleitringdichtung aus Keramik/Graphit. Antriebswelle aus rostfreiem Stahl. Diffusoren aus Noryl. Die Pumpen CM haben Laufräder aus rostfreiem Stahl, Manometrische Saughöhe bis zu 3 Meter; das Modell JET 5-120 hat Laufräder aus Noryl und ist **selbstansaugende mit Manometrische Saughöhe: 8 Meter**.
 Einphasenspannung mit thermischen Motorschutz. Das Modell CM 200 ist auch in Dreiphasenspannung 230/400V mit Motorvollschutz nach Benutzersorge lieferbar. IP 44 Schutz. Isol. Klasse F. Max temperatur der Flüssigkeit : 40 °C.

Modello Model Modèle Modell	Potenza Power Puissance Pferdestärke		Tensione Voltage Bobinage Spannung V-Hz-ph	A	Giranti Impellers Roues Laufräder N.	Portata - Capacity - Débit - Fördermenge (l/min)						
	HP	kW				0	20	40	60	80	100	120
						Prevalenza - Head - Hauteur - Förderhöhe (m)						
CM 80	0,8	0,59	230-50-1	5,0	3	39	35	30	22	13		
CM 100	1	0,75	230-50-1	6,6	4	49	46	41	34	25	13	
CM 200	2	1,5	230-50-1	10,0	5	60	55	51	45	38	30	19
			230/400-50-3	6,6/3,8								
JET 5-120	1,2	0,9	230-50-1	6,0	5	58	55	50	40	23		

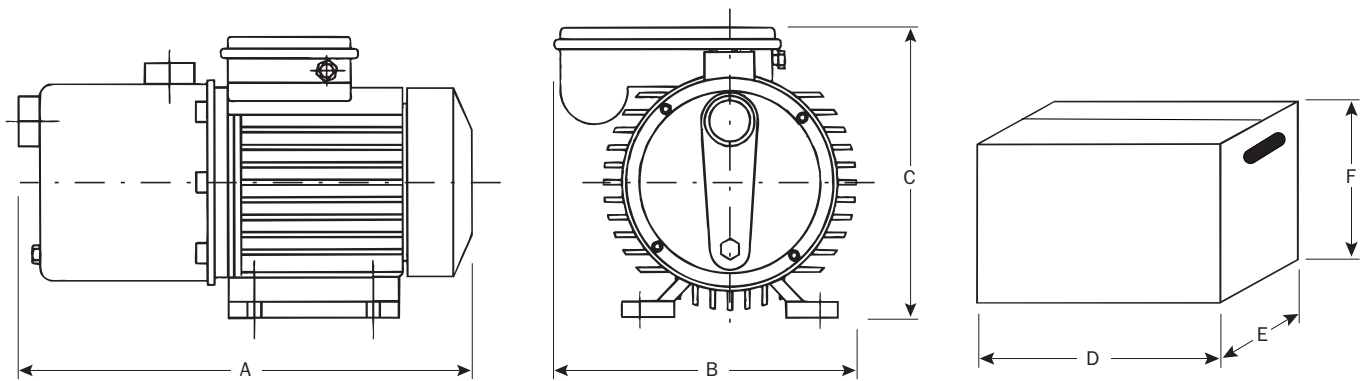
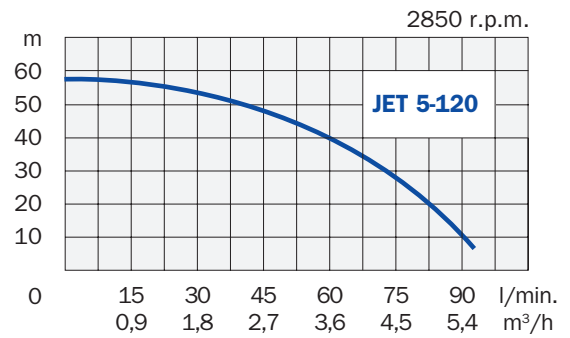
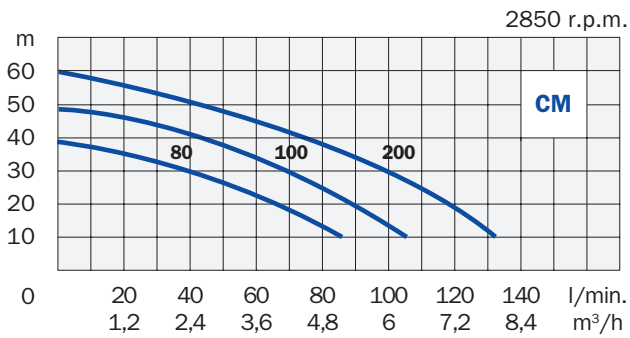

Modello Model Modèle Modell	Aspirazione Suction Aspiration Saug-Seite	Mandata Discharge Refoulement Druck-Seite	Dimensioni - Dimensions - Masstabelle						Peso Weight Poids Gewicht kg
			mm						
			A	B	C	D	E	F	
CM 80	1" - DN 25	1" - DN 25	350	170	182	390	175	210	9
CM 100	1" - DN 25	1" - DN 25	370	170	182	390	175	210	11
CM 200	1"1/4 M - DN 32	1" F - DN 25	420	195	210	425	210	250	15
JET 5-120	1" - DN 25	1" - DN 25	415	206	212	450	210	240	13

POMPE MULTICELLULARI ORIZZONTALI IN AISI 304

MULTISTAGE HORIZONTAL PUMPS IN AISI 304

SERIE CMX



 Pompe centrifughe multicellulari professionali ideali per la pressurizzazione dell'acqua negli impianti domestici e per irrigazione. Funzionamento silenzioso. Aspirazione fino a 3 metri.

Tutti i componenti interni della pompa (corpo pompa, giranti e diffusori) sono in acciaio AISI 304, su richiesta disponibili anche in AISI 316. Tenuta meccanica in ceramica / grafite / EPDM, su richiesta disponibile in carburo di silicio / Viton. Motore chiuso autoventilato. Albero in acciaio. Tensione monofase con protezione termica incorporata. Tensione trifase 230/400V con protezione a cura dell'utente.

Massima pressione di lavoro: 10bar; Massimo contenuto di sabbia: 50 gr/m³.

Protezione IP55; Classe di isolamento F; temperatura massima dell'acqua da pompare: 110 °C.

 Professional multistage centrifugal pumps suitable for the raising and the distribution of water in domestic and commercial plants and for small irrigation systems. Quiet running. Suction head up to 3 metres depth.

All the internal components of the pump (pump body, impellers and diffusers) are in stainless steel AISI 304, on request also available in AISI 316. Mechanical seal in ceramic / carbon / EPDM, on request available in silicon carbide / Viton. Closed self-ventilated motor. Shaft in stainless steel. Single-phase voltage with built-in motor protector. Three-phase voltage 230/400V must be protected by a fused remote isolator switch.

Maximum working pressure: 10bar; maximum sand content: 50 gr/m³.

Protection class IP 55; Insulation class F; max. temperature of pumped water 230 °F (110 °C).

 Pompes centrifuges multicellulaires indiquées pour la distribution d'eau dans les installations domestiques et commerciales et pour d'irrigations. Fonctionnement très silencieux. Aspiration jusqu'à 3 mètres de profondeur.

Tous les composants (corps de pompe, roues et diffuseurs) sont en acier inox AISI 304, à la demande les pompes peuvent être fournies en acier inox AISI 316. Garniture mécanique en céramique / graphite / EPDM, à la demande aussi en carbure de silicium / Viton. Moteur enfermé avec ventilation extérieure. Arbre en acier inox. Bobinage monophasé avec protection thermique incorporée. Bobinage triphasé 230/400V avec protection par l'utilisateur.

Maximum pression de service: 10bar ; Max contenu de sable: 50 gr/m³.

Protection IP55 ; Isolation classe F ; température max. de l'eau pompée : 110 °C

 Mehrstufige Kreiselpumpen zur Hauswasser Versorgung, zur Bewässerung usw. Geräuschloser Betrieb. Manometrische Saughöhe bis zu 3 Meter. Alle Komponenten (Pumpengehäuse, Laufräder und Diffusoren) sind aus rostfreiem Stahl AISI 304, auf Wunsch aus rostfreiem Stahl AISI 316 lieferbar. Gleitringdichtung aus Keramik / Graphit / EPDM, auf Wunsch aus Siliziumkarbid / Viton lieferbar. Antriebswelle aus rostfreiem Stahl. Einphasenspannung mit thermischen Motorschutz. Dreiphasenspannung 230/400V mit Motorvollschutz nach Benutzersorge lieferbar.

Maximaler Betriebsdruck: 10 bar; Max Sanddichte: 50 gr/m³

IP 55 Schutz. Isol. Klasse F. Max Temperatur der Flüssigkeit: 110 °C.

Modello Model Modèle Modell	Potenza Power Puissance Pferdestärke		Tensione Voltage Bobinage Spannung	A	Nr. stadi N. stages N. étages Stufenzahl	Prevalenza - Head - Hauteur - Förderhöhe (m)						
	HP	kW	V-Hz-ph			Portata - Capacity - Débit - Fördermenge (l/min)						
CMX05	HP	kW	V-Hz-ph	A.	N.	0	20	30	40	50	60	70
CMX05 60	0,60	0,45	230-50-1	3,0	3	34	31	29	27	23	19	14
			230/400-50-3	2,1/1,2								
CMX05 75	0,75	0,55	230-50-1	3,7	4	45	41	38	35	30	25	19
			230/400-50-3	2,4/1,4								
CMX05 100	1,0	0,75	230-50-1	4,3	5	55	50	47	42	37	30	24
			230/400-50-3	2,7/1,6								
CMX05 150	1,5	1,1	230-50-1	6,0	7	78	73	68	60	53	45	36
			230/400-50-3	3,6/2,1								
CMX05 200	2,0	1,5	230-50-1	7,5	9	102	94	88	80	71	60	48
			230/400-50-3	5,1/3,0								
CMX08	HP	kW	V-Hz-ph	A.	N.	0	20	40	60	80	100	120
CMX08 75	0,75	0,55	230-50-1	3,9	3	32	30	28	25	22	17	10
			230/400-50-3	2,5/1,4								
CMX08 120	1,2	0,9	230-50-1	5,3	4	45	42	39	37	32	27	18
			230/400-50-3	3,2/1,9								
CMX08 150	1,5	1,1	230-50-1	6,2	5	56	53	49	45	38	34	23
			230/400-50-3	3,7/2,2								
CMX08 180	1,8	1,3	230-50-1	7,3	6	68	65	62	57	48	41	28
			230/400-50-3	5,0/2,9								
CMX08 200	2,0	1,5	230-50-1	10,5	8	91	86	82	74	62	52	34
			230/400-50-3	6,8/3,9								
CMX15	HP	kW	V-Hz-ph	A.	N.	0	40	80	120	160	200	240
CMX15 100	1,0	0,75	230-50-1	4,3	2	24	22	20	18	16	12	5
			230/400-50-3	2,7/1,6								
CMX15 150	1,5	1,1	230-50-1	6,3	3	36	34	31	28	24	19	10
			230/400-50-3	3,7/2,2								
CMX15 200	2,0	1,5	230-50-1	8,2	4	48	46	43	38	32	26	14
			230/400-50-3	5,5/3,2								
CMX15 250	2,5	1,9	230-50-1	11,1	5	60	56	53	48	40	32	18
			230/400-50-3	7,1/4,1								
CMX15 300	3,0	2,2	230-50-1	14,5	7	84	79	75	69	60	48	24
			230/400-50-3	9,5/5,5								

*On request other voltages are available

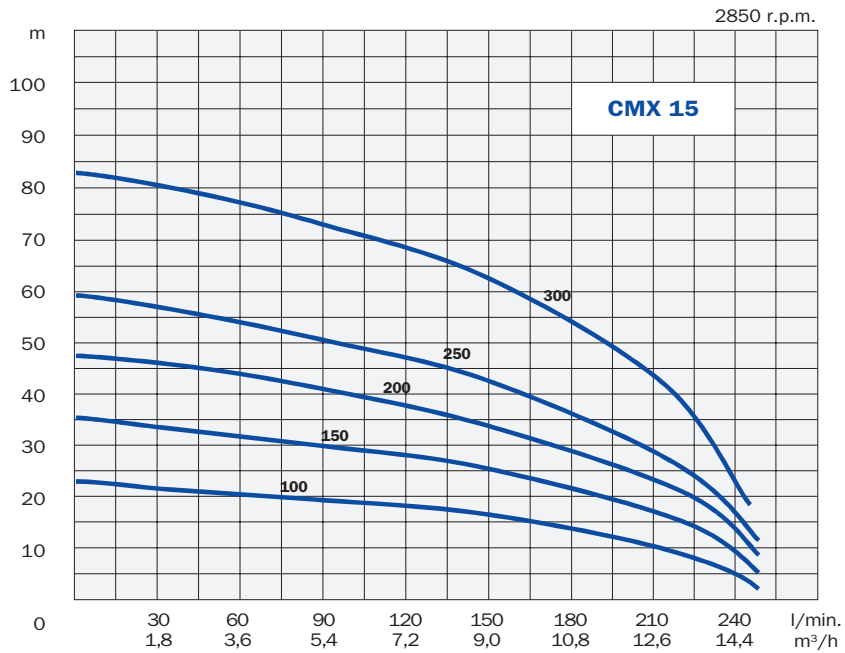
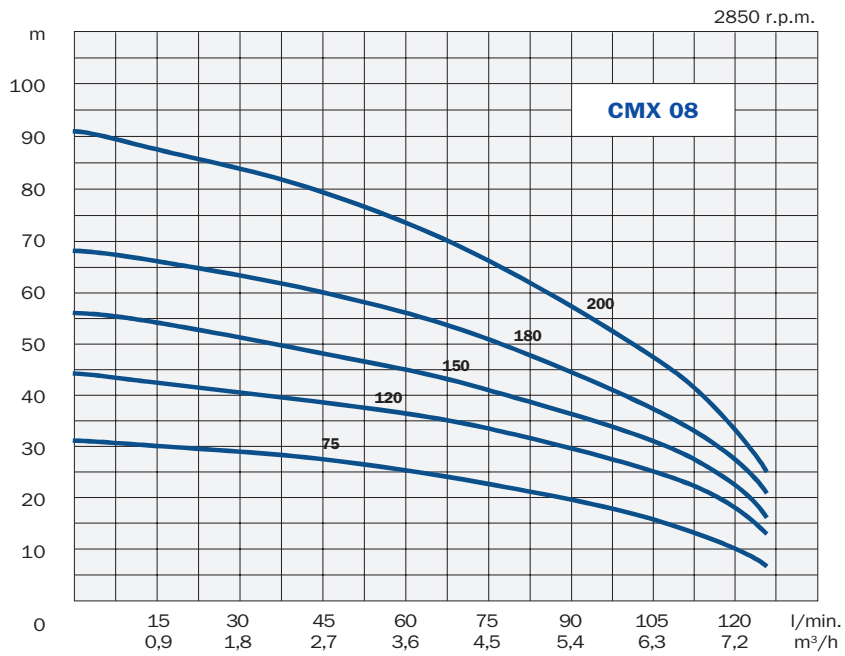
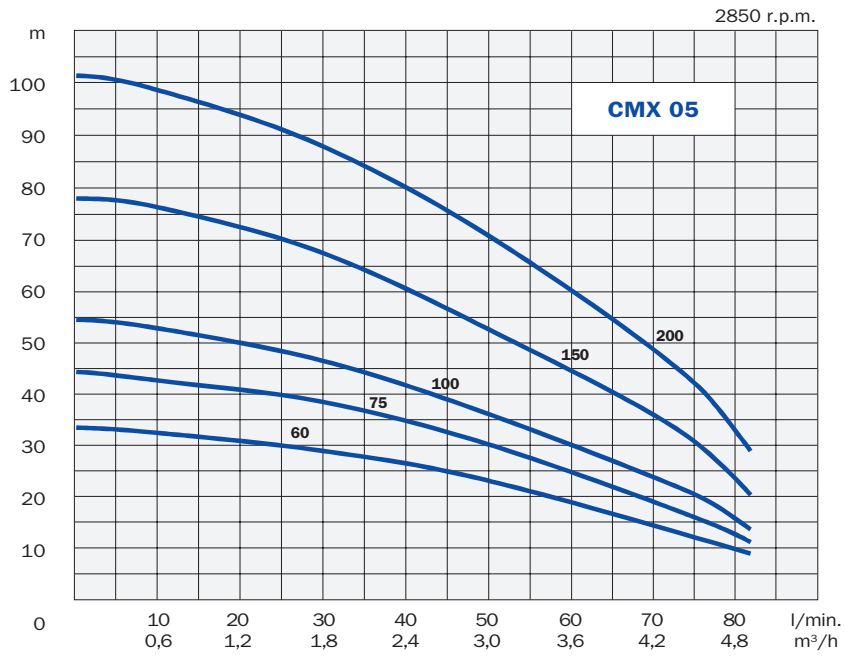

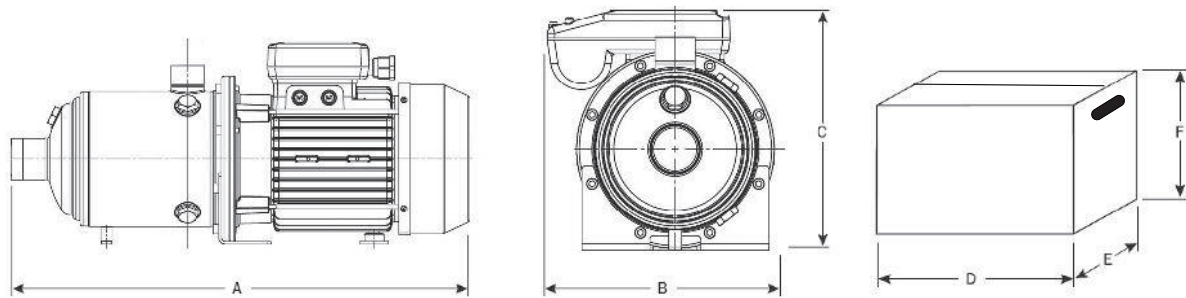

Modello Model Modèle Modell	Aspirazione Suction Aspiration Saug-Seite	Mandata Discharge Refoulement Druck-Seite	Dimensioni - Dimensions - Masstabelle mm						Peso Weight Poids Gewicht kg
			A	B	C	D	E	F	
CMX05									
CMX05 60	1"1/4	1"	361	204	207	420	220	230	11
CMX05 75	1"1/4	1"	385	204	207	420	220	230	12
CMX05 100	1"1/4	1"	409	204	207	420	220	230	13
CMX05 150	1"1/4	1"	457	204	207	480	220	230	15
CMX05 200	1"1/4	1"	547	204	214	600	220	230	19
CMX08									
CMX08 75	1"1/4	1"	361	204	207	420	220	230	12
CMX08 120	1"1/4	1"	385	204	207	420	220	230	13
CMX08 150	1"1/4	1"	409	204	207	480	220	230	14
CMX08 180	1"1/4	1"	475	204	214	600	220	230	18
CMX08 200	1"1/4	1"	523	204	214	600	220	230	22
CMX15									
CMX15 100	1"1/2	1"1/4	380	177	207	420	200	230	12
CMX15 150	1"1/2	1"1/4	380	177	207	420	200	230	13
CMX15 200	1"1/2	1"1/4	452	177	214	480	200	230	17
CMX15 250	1"1/2	1"1/4	527	177	221	600	200	230	23
CMX15 300	1"1/2	1"1/4	587	177	221	600	200	230	25

POMPE MULTICELLULARI VERTICALI

MULTISTAGE VERTICAL PUMPS

SERIE CMV



-  Pompe centrifughe multistadio verticali.
Silenziose e ad alto rendimento. Particolarmente indicate per gruppi di pressurizzazione nelle installazioni civili e industriali, per impianti di lavaggio e per irrigazione. Aspirazione fino a 3 metri.
Corpo di aspirazione e mandata in ghisa. Camicia ed albero in acciaio. Giranti in acciaio. Diffusori in policarbonato con fibra di vetro. Tenuta meccanica in ceramica/grafite. Motore chiuso autoventilato.
Protezione termica incorporata sulle pompe con voltaggio monofase; sui modelli con voltaggio trifase protezione a cura dell'utente.
Protezione IP 44. Isolamento classe F. Temperatura massima dell'acqua da pompare 40 °C.

-  Multi-stage centrifugal pumps vertical type.
Quiet running. High performance. Particularly suitable for pressure boosting systems in domestic and industrial plants, as well as for car-washing plants, irrigation plants, etc. Suction head up to 3 metres depth.
Pump body and pump discharge in cast iron. Housing and shaft in stainless steel. Impellers in stainless steel. Diffusers in polycarbonate with glass fiber. Mechanical seal in ceramic/graphite. Closed self-ventilated motor.
Built-in motor protector on single-phase models; the three-phase pumps must be protected by a fused remote isolator switch.
Protection class IP 44. Insulation class F. Max. temperature of pumped water 104 °F (40 °C).

-  Pompes centrifuges multicellulaires verticales indiquées pour la distribution d'eau dans les installations domestiques et industrielles.
Particulièrement conseillées pour groupes surpresseurs et installations de lavage et irrigation. Fonctionnement très silencieux. Rendement élevé. Aspiration jusqu'à 3 mètres de profondeur.
Corps d'aspiration et de refoulement en fonte. Calotte et arbre en acier inox. Roues en acier inox. Diffuseurs en polycarbonate avec fibre de ver. Garniture mécanique en céramique/graphite. Moteur enfermé avec ventilation extérieure.
Protection thermique incorporée sur les modèles avec bobinage monophasé; protection par l'utilisateur sur les modèles triphasés.
Protection IP 44. Isolation classe F. Température max. de l'eau pompée 40 °C.

-  Vertikale- mehrstufige- Kreiselpumpen.
Einsatzgebiete: zur Beregnung; Speziell zur Verwendung in Druckerhöhungsanlage. Geräuschloser Betrieb.
Manometrische Saughöhe bis zu 3 Meter.
Saug- und Druckgehäuse aus Grauguß. Pumpenmantel und Antriebswelle aus rostfreiem Stahl. Laufräder aus rostfreiem Stahl. Diffusoren aus Polycarbonat mit Glasfaser. Keramik/Graphit Gleitringdichtung.
Thermischen Motorschutz bei Pumpen mit Einphasenspannung; Motorschutz nach Benutzersorge bei Pumpen mit Dreiphasenspannung.
IP 44 Schutz. Isol. Klasse F. Max. Temperatur der Flüssigkeit: 40 °C.

Modello Model Modèle Modell	Potenza Power Puissance Pferdestärke		Tensione Voltage Bobinage Spannung V-Hz-ph	A	Nr. stadi N. stages N. étages Stufenzahl N.	Portata - Capacity - Débit - Fördermenge (l/min)							
	HP	kW				0	25	50	75	100	125	150	175
	Prevalenza - Head - Hauteur - Förderhöhe (m)												
CMV 150	1,5	1,1	230-50-1	8,4	4	56	52	48	42	35	27	19	
			230/400-50-3	5,3/3,1									
CMV 200	2	1,5	230-50-1	10,2	5	68	65	60	53	46	36	24	
			230/400-50-3	6,9/4									
CMV 300	3	2,2	230/400-50-3	8,3/4,8	6	82	80	76	69	60	49	36	
CMV 400	4	3	230/400-50-3	11,9/6,5	8	110	105	98	88	77	63	46	25
CMV 550	5,5	4	230/400-50-3	15,4/8,9	10	140	134	128	117	105	90	71	45

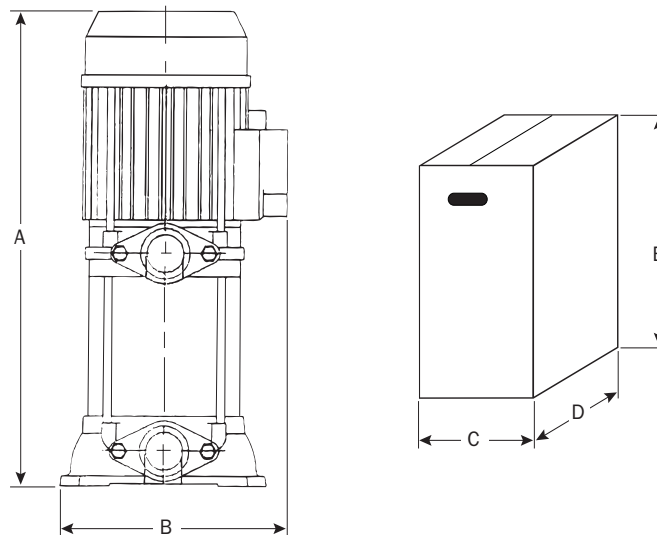
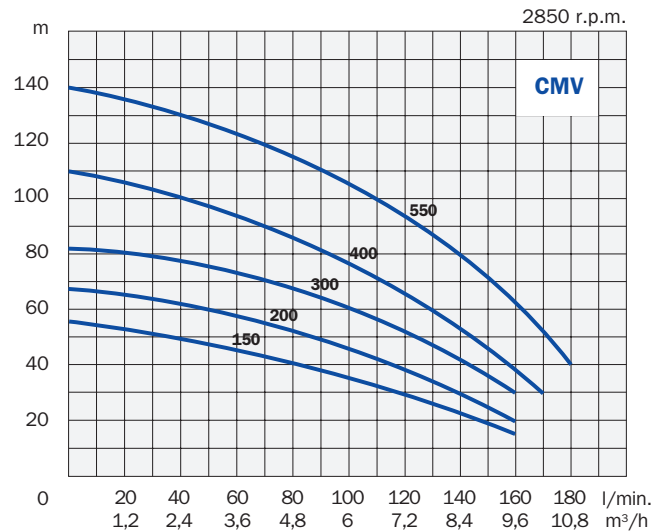

Modello Model Modèle Modell	Aspirazione Suction Aspiration Saug-Seite	Mandata Discharge Refoulement Druck-Seite	Dimensioni - Dimensions - Masstabelle					Peso Weight Poids Gewicht
			mm					
			A	B	C	D	E	
CMV 150	1"1/2 - DN 40	1"1/4 - DN 32	512	203	210	270	650	22
CMV 200	1"1/2 - DN 40	1"1/4 - DN 32	536	203	210	270	650	25
CMV 300	1"1/2 - DN 40	1"1/4 - DN 32	561	203	210	270	650	26
CMV 400	1"1/2 - DN 40	1"1/4 - DN 32	658	233	225	310	795	33
CMV 550	1"1/2 - DN 40	1"1/4 - DN 32	708	233	225	310	795	39

POMPE MULTICELLULARI VERTICALI IN-LINE

IN-LINE MULTISTAGE VERTICAL PUMPS

SERIE CMV SS



 Pompe centrifughe multistadio verticali con attacchi in-line. Silenziose e ad alto rendimento. Aspirazione fino a 3 metri. Particolarmente indicate per gruppi di pressurizzazione nelle installazioni civili ed industriali, per impianti di lavaggio ed irrigazione. Gli attacchi in-line consentono un'installazione molto semplice della pompa.

Corpo di aspirazione e mandata in acciaio AISI 304. Camicia pompa, coperchio superiore, coperchio inferiore e controflange in acciaio AISI 304. Giranti e diffusori in acciaio AISI 304. Tenuta meccanica in grafite/silicio.

Motore chiuso autoventilato. Albero motore in acciaio AISI 303. Voltaggio trifase con protezione a cura dell'utente. Protezione IP 55. Isolamento classe F. Temperatura massima dell'acqua da pompare 110 °C.

 Multi-stage centrifugal pumps vertical type with in-line connections. Quiet running, high performance. Suction head up to 3 metres depth. Particularly suitable for pressure boosting systems in domestic and industrial plants, as well as for car-washing plants, irrigation plants, etc. The in-line connections allow a very easy installation of the pump.

Suction and discharge body in stainless steel AISI 304. Pump housing, upper cover, lower cover and counterflanges in stainless steel AISI 304. Impellers and diffusers in stainless steel AISI 304. Mechanical seal in silicon/graphite.

Closed self-ventilated motor. Motor shaft in stainless steel AISI 303. Three-phase voltage: the pumps must be protected by a fused remote isolator switch. Protection class IP 55. Insulation class F. Max. temperature of pumped water 230 °F (110 °C).

 Pompes centrifuges multicellulaires verticales avec connections in-line indiquées pour la distribution d'eau dans les installations domestiques et industrielles. Aspiration jusqu'à 3 mètres de profondeur. Particulièrement conseillées pour groupes surpresseurs et installations de lavage et irrigation. Les connections in-line permettent une installation très facile de la pompe.

Corps d'aspiration et de refoulement en acier inox AISI 304. Calotte, couvercle supérieur, couvercle inférieur et contre brides en acier inox AISI 304. Roues et diffuseurs en acier inox AISI 304. Garniture mécanique en carbure de silicium/graphite.

Moteur enfermé avec ventilation extérieure. Arbre moteur en acier inox AISI 303. Bobinage triphasé avec protection par l'utilisateur. Protection IP 55. Isolation classe F. Température max. de l'eau pompée 110 °C.

 Vertikale-mehrstufige-Kreiselpumpen mit in-line Verbindungen. Einsatzgebiete: zur Beregnung; Speziell zur Verwendung in Druckerhöhungsanlage. Geräuschloser Betrieb. Manometrische Saughöhe bis zu 3 Meter. Die in-line Verbindungen ermöglichen eine einfache Montage der Pumpen.

Saug- und Druckgehäuse aus rostfreiem Stahl AISI 304. Pumpenmantel, Ober- und Unterdeckel, Gegenflansche aus rostfreiem Stahl AISI 304. Laufräder und Diffusoren aus rostfreiem Stahl AISI 304. Siliziumkarbid/Graphit Gleitringdichtung.

Antriebswelle aus rostfreiem Stahl AISI 303. Dreiphasenspannung mit Motorschutz nach Benutzersorge. IP 55 Schutz. Isol. Klasse F. Max. Temperatur der Flüssigkeit: 110 °C.

Modello Model Modèle Modell	Potenza Power Puissance Pferdestärke		Tensione Voltage Bobinage Spannung	A	Nr. stadi N. stages N. étages Stufenzahl	Prevalenza - Head - Hauteur - Förderhöhe (m)					
	HP	kW	V-Hz-ph			A.	N.	Portata - Capacity - Débit - Fördermenge (l/min)			
CMV SS12	HP	kW	V-Hz-ph	A.	N.	0	40	80	120	160	200
CMV SS12 300	3	2,2	230/400-50-3	7,8/4,5	6	68	65	62	57	50	32
CMV SS12 550	5,5	4	230/400-50-3	12,1/7,0	10	112	110	104	94	83	67
CMV SS12 750	7,5	5,5	230/400-50-3	17,8/10,3	15	153	150	145	134	120	99
CMV SS12 1000	10	7,5	400/690-50-3	13,5/7,8	19	199	198	193	181	161	126
CMV SS22	HP	kW	V-Hz-ph	A.	N.	0	80	160	240	320	367
CMV SS22 550	5,5	4	230/400-50-3	12,1/7,0	4	58	56	52	45	39	34
CMV SS22 750	7,5	5,5	230/400-50-3	17,8/10,3	6	84	83	80	73	61	53
CMV SS22 1000	10	7,5	400/690-50-3	13,5/7,8	8	116	113	107	95	81	71
CMV SS22 1500	15	11	400/690-50-3	20,0/11,5	12	173	170	163	146	120	104
CMV SS40	HP	kW	V-Hz-ph	A.	N.	0	120	240	360	480	667
CMV SS40 1000	10	7,5	400/690-50-3	13,5/7,8	4	80	79	74	68	58	37
CMV SS40 1500	15	11	400/690-50-3	20,0/11,5	6	118	116	110	100	85	55
CMV SS40 2000	20	15	400/690-50-3	26,5/15,3	8	150	149	145	133	116	74
CMV SS40 2500	25	18,5	400/690-50-3	32,2/18,6	10	193	192	184	169	149	97

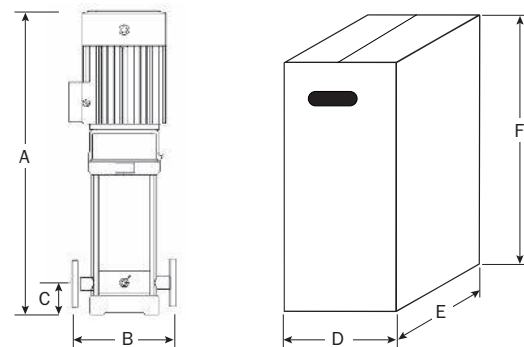
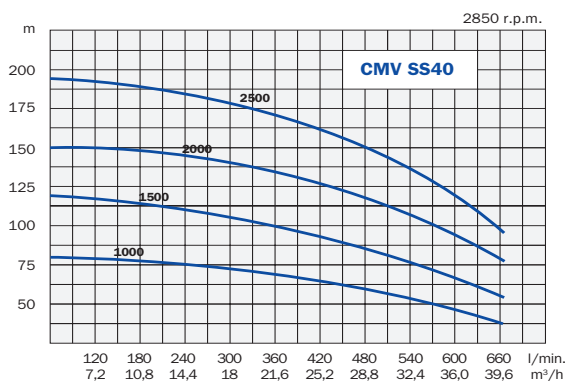
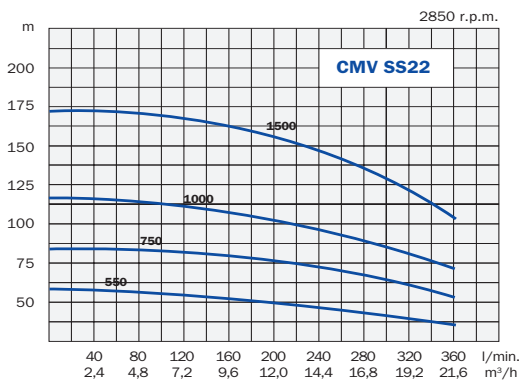
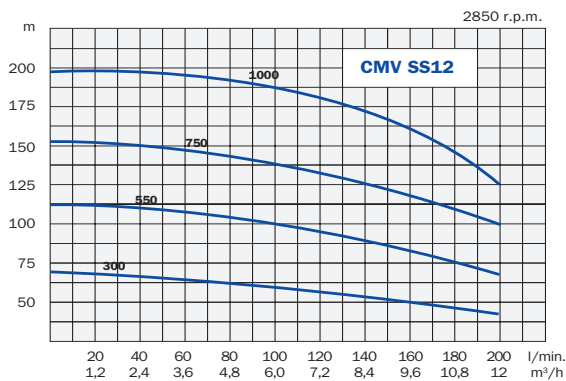

Modello Model Modèle Modell	Aspirazione Suction Aspiration Saug-Seite	Mandata Discharge Re foulement Druck-Seite	Dimensioni - Dimensions - Masstabelle						Peso Weight Poids Gewicht
			mm						
			A	B	C	D	E	F	
CMV SS12 300	1"1/2 - DN 40	1"1/2 - DN 40	767	280	80	350	350	950	63
CMV SS12 550	1"1/2 - DN 40	1"1/2 - DN 40	942	280	80	400	350	1200	88
CMV SS12 750	1"1/2 - DN 40	1"1/2 - DN 40	1237	280	80	500	400	1500	120
CMV SS12 1000	1"1/2 - DN 40	1"1/2 - DN 40	1297	280	80	500	400	1500	122
CMV SS22 550	2" - DN 50	2" - DN 50	832	300	90	350	350	950	85
CMV SS22 750	2" - DN 50	2" - DN 50	1037	300	90	400	350	1200	110
CMV SS22 1000	2" - DN 50	2" - DN 50	1127	300	90	400	350	1200	120
CMV SS22 1500	2" - DN 50	2" - DN 50	1455	300	90	500	400	1500	205
CMV SS40 1000	2"1/2 - DN 65	2"1/2 - DN 65	1145	320	105	400	350	1200	150
CMV SS40 1500	2"1/2 - DN 65	2"1/2 - DN 65	1450	320	105	500	400	1500	230
CMV SS40 2000	2"1/2 - DN 65	2"1/2 - DN 65	1590	320	105	500	400	1700	258
CMV SS40 2500	2"1/2 - DN 65	2"1/2 - DN 65	1790	320	105	500	400	1900	290

GRUPPI DI PRESSURIZZAZIONE

PRESSURE BOOSTING SYSTEMS

BOOSTER SUPERJET
150-300



BOOSTER 2C 400



BOOSTER CMV 300-550

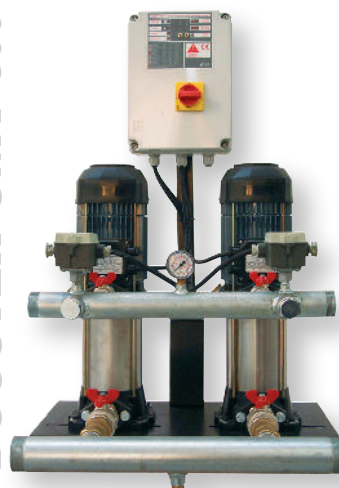

I gruppi di pressurizzazione con due pompe sono particolarmente indicati per impianti civili, industriali ed agricoli, sia per l'approvvigionamento di acqua, sia per impianti di riscaldamento, di condizionamento e di raffreddamento, come pure per impianti di irrigazione.

Uno scambiatore elettronico comanda l'avviamento alternato delle due pompe ed il funzionamento contemporaneo in caso di maggior richiesta d'acqua.

Il gruppo è composto da due elettropompe, collettori di aspirazione e mandata, valvole di ritegno e di intercettazione in aspirazione ed in mandata, pressostati, manometro, quadro elettrico con selettore di comando per ogni singola pompa. Su richiesta possono essere forniti anche due vasi di espansione.



The pressure boosting systems with two pumps are particularly recommended in the domestic, industrial and agricultural fields, for heating, cooling, irrigation.

An electronic exchanger alternates pumps starting, as well as the simultaneous working of both the pumps in case of a larger demand of water.

The system consists of two pumps, inlet and outlet steel collectors, check valves and butterfly valves, pressure switches, a pressure gauge, electric switch board with selector for automatic or manual operation for each pump. On request can be supplied also two pressure tanks.



Groupes surpresseurs pour la distribution automatique d'eau sous pression dans des installations civiles, industrielles, de chauffage, de conditionnement, de refroidisseur, d'irrigation, etc.

Le groupe est composé de deux pompes, d'un collecteur d'aspiration et de refoulement, de deux pressostats, d'un manomètre, de deux soupapes de retenue soit en aspiration que en refoulement.

Le tableau électrique fait démarrer les deux pompes alternativement et, le cas d'une plus grande demande d'eau, il fait fonctionner les deux pompes en même temps.

A la demande on peut livrer aussi les réservoirs.



Die Druckerhöhungsanlagen mit zwei Pumpen werden besonders für Zivilbauanlagen, den Industrie- und Landwirtschaftsbereich sowohl für die Wasserversorgung, als auch für Heiz-, Klima- und Kühlanlagen und außerdem für Bewässerungs- und Brandlöschanlagen empfohlen.

Ein elektrischer Austausch bestimmt den abwechselnden Anlauf der beiden Pumpen und ihren gleichzeitigen Betrieb im Fall eines erhöhten Wasserbedarfs.

Die Einheit besteht aus zwei Elektropumpen, Eingangs- und Ausgangskollektoren, Rückschlag- und Absperrventile am Ein- und Ausgang, Druckregler, Manometer, Schaltfeld gemäß CEI-Normen mit Gruppenwähler für jede einzelne Pumpe. Auf Nachfrage können auch zwei Druckbehälter geliefert werden.

Modello Model Modèle Modell	Potenza Power Puissance Pferdestärke HP kW		Tensione Voltage Bobinage Spannung V-Hz-ph	A	Portata - Capacity - Débit - Fördermenge (l/min)									
					50	75	100	125	150	175	200	225	250	275
					Prevalenza - Head - Hauteur - Förderhöhe (m)									
BOOSTER SUPERJET 150	2x1,5	2x1,1	230-50-1	2x8,5	43	40	34	30	27	21	14			
			230/400-50-3	2x8,0/4,6										
BOOSTER SUPERJET 200	2x2	2x1,5	230-50-1	2x9,4	48	45	42	37	33	27	22	14		
			230/400-50-3	2x8,5/4,9										
BOOSTER SUPERJET 300	2x3	2x2,2	230-50-1	2x11,9	57	53	49	46	40	34	29	22		
			230/400-50-3	2x8,7/5,0										
BOOSTER 2C 400	2x4	2x3	230/400-50-3	2x14,0/8,0	72	70	67	65	62	58	56	52	47	42
BOOSTER CMV 300	2x3	2x2,2	230/400-50-3	2x8,3/4,8	79	77	73	69	64	61	53	45	36	
BOOSTER CMV 400	2x4	2x3	230/400-50-3	2x11,9/6,5	103	98	93	88	83	76	69	60	52	42
BOOSTER CMV 550	2x5,5	2x4	230/400-50-3	2x15,4/8,9	132	128	124	118	112	105	98	89	75	65

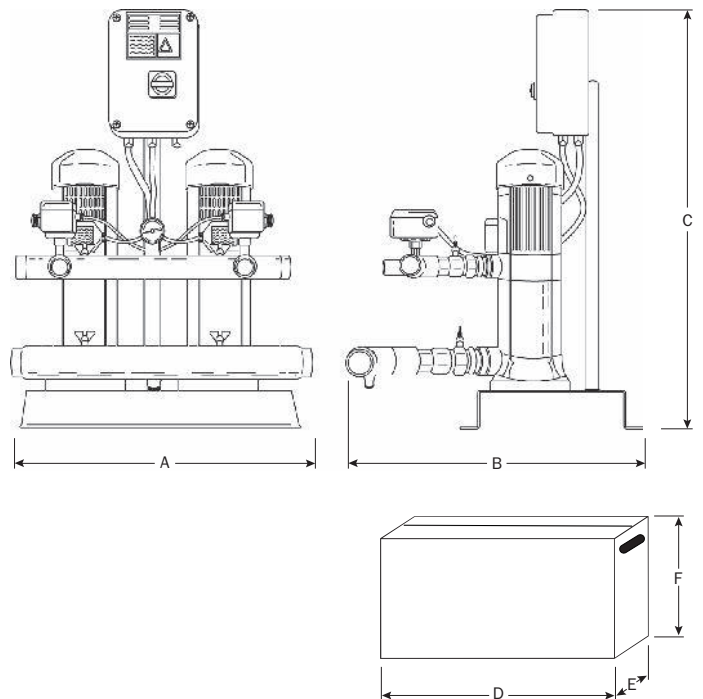
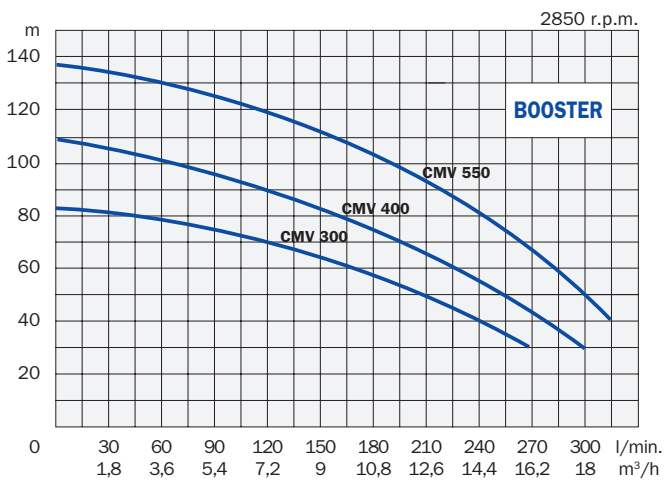
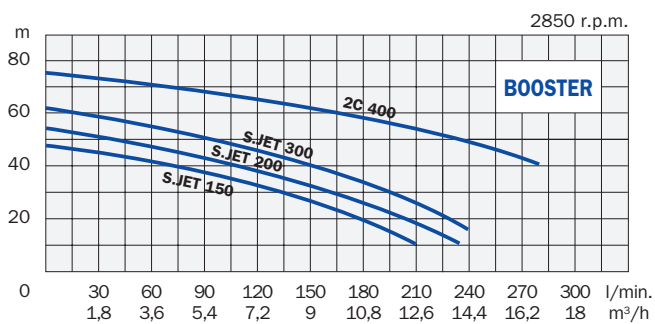



Modello Model Modèle Modell	Aspirazione Suction Aspiration Saug-Seite	Mandata Discharge Refolement Druck-Seite	Dimensioni - Dimensions - Masstabelle						Peso Weight Poids Gewicht kg
			mm						
			A	B	C	D	E	F	
BOOSTER SUPERJET 150	2"1/2-DN 65	2"-DN 50	615	1000	750	800	730	900	98
BOOSTER SUPERJET 200	2"1/2-DN 65	2"-DN 50	615	1000	750	800	730	900	100
BOOSTER SUPERJET 300	2"1/2-DN 65	2"-DN 50	615	1000	750	800	730	900	102
BOOSTER 2C 400	2"1/2-DN 65	2"-DN 50	700	800	750	800	730	900	118
BOOSTER CMV 300	2"1/2-DN 65	2"-DN 50	615	730	750	800	600	900	86
BOOSTER CMV 400	2"1/2-DN 65	2"-DN 50	615	730	750	800	600	900	100
BOOSTER CMV 550	2"1/2-DN 65	2"-DN 50	615	730	750	800	600	900	112

POMPE AUTOADESCANTI PER DRENAGGIO

SELF-PRIMING PUMPS FOR DRAINAGE

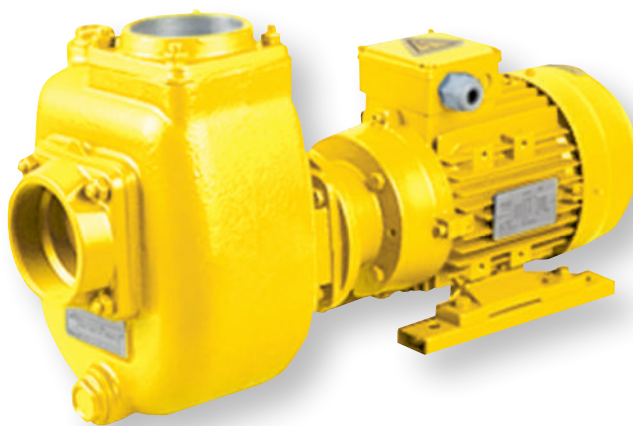
SERIE E



-  Pompe autoadescenti per il drenaggio di acque sporche con corpi solidi. Trovano varie applicazioni nell'edilizia ed in agricoltura per il prosciugamento, l'irrigazione, ecc. Aspirazione fino a 4 metri.
Corpo pompa in ghisa. Girante in ghisa a pale aperte. Valvola a clapet incorporata. Tenuta meccanica in carburo di silicio.
È disponibile anche l'allestimento su carrello a due ruote.
Su richiesta sono disponibili pompe di potenze superiori a quelle indicate.
Disponibili anche pompe con motore a benzina o diesel.

-  Self-priming pumps designed for the drainage of dirty water with solid parts. They are also suitable for big dewatering in contractor sites, for irrigation, transferring liquids and for many other purposes. Suction head up to 4 metres depth.
Pump body in cast-iron. Open wings impeller in cast-iron. Built-in clapet valve. Mechanical seal in silicon carbide.
It is also available the arrangement with two wheels trailer.
On request are available upper models.
Available also pumps with petrol or diesel engine.

-  Pompes autoamorçantes pour d'importants drainages d'eaux chargées, sablonneuses et boueuses dans les chantiers de construction, pour vider des caves, des passages souterrains ainsi que pour irrigation. Aspiration jusqu'à 4 mètres de profondeur.
Corps de pompe en fonte. Roue en fonte de type ouvert. Soupape clapet incorporée. Garniture mécanique en carbure de silicium.
Les pompes sont disponibles aussi avec chariot tracteur à deux roues.
A la demande on peut livrer aussi des modèles avec puissances plus élevées.
On peut livrer aussi des modèles avec moteur à essence ou diesel.

-  Selbstansaugende Pumpen zur Drainage von Schmutzwasser mit Festkörpern, zur Bewässerung und für viele andere Zwecke. Manometrische Saughöhe bis zu 4 Meter.
Pumpengehäuse aus Grauguß. Offeneslaufrad aus Grauguß. Eingebautes Rückschlagventil. Gleitringdichtung aus Silizium-Karbid.
Es ist einem zweirädrigen Fahrgestell lieferbar.
Auf Wunsch sind Pumpen mit höheren Pferdestärken lieferbar.
Auf Wunsch sind Pumpen mit Benzinmotor oder Dieselmotor.

Modello Model Modèle Modell	Potenza Power Puissance Pferdestärke		Tensione Voltage Bobinage Spannung V-Hz-ph	A	Portata - Capacity - Débit - Fördermenge (l/min)								
	HP	kW			0	250	500	750	1000	1250	1500	1750	
					Prevalenza - Head - Hauteur - Förderhöhe (m)								
E 150	1,5	1,1	230-50-1	7,2	14	12	3						
E 300	3,0	2,2	230/400-50-3	9,1/5,2	14	13	10	8	5				
E 550	5,5	4,0	230/400-50-3	14,8/8,6	15	14	13	11	10	8	7	5	

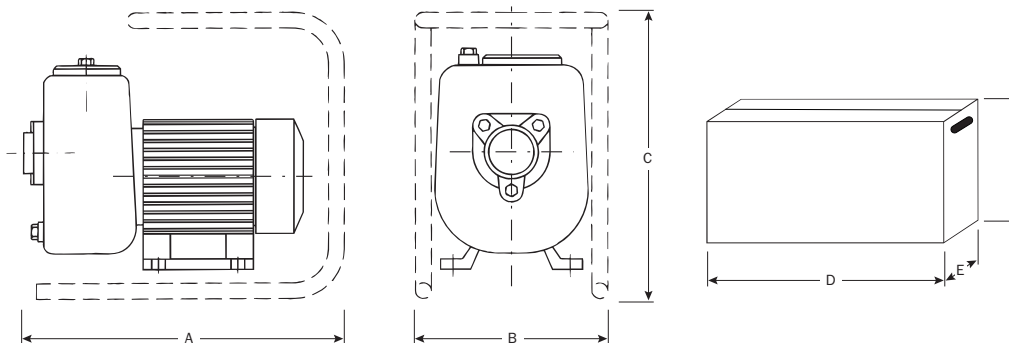
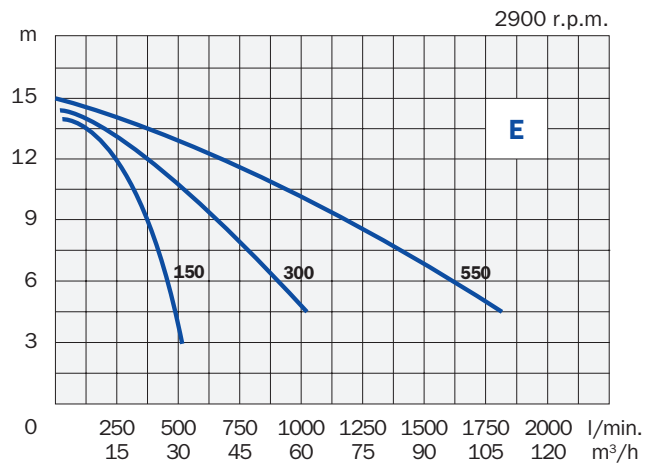



Modello Model Modèle Modell	Aspirazione Suction Aspiration Saug-Seite	Mandata Discharge Refoulement Druck-Seite	Corpi solidi Solid parts Corps solides Festkörper mm	Dimensioni - Dimensions - Masstabelle mm						Peso Weight Poids Gewicht kg
				A	B	C	D	E	F	
				E 150	2" - DN 50	2" - DN 50	18	450	205	
E 300	3" - DN 80	3" - DN 80	25	535	230	300	580	260	350	31
E 550	4" - DN 100	4" - DN 100	38	660	300	380	710	330	430	60

POMPE AUTOADESCANTI PER ACQUE SPORCHE

SELF-PRIMING PUMPS FOR SEWAGE WATER

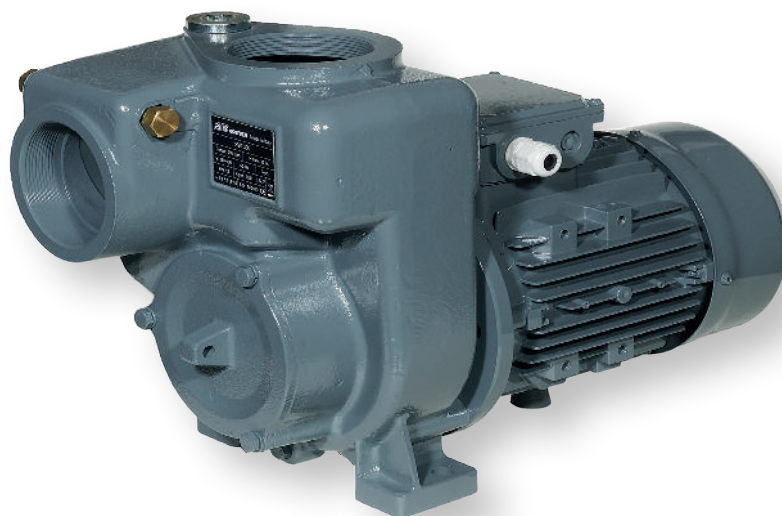
SERIE SW



-  Pompe autoadescenti con girante aperta e sportello di ispezione. Valvola a clapet in aspirazione. Utilizzabili per il pompaggio di liquidi sporchi contenenti corpi solidi. Corpo pompa, supporto e girante in ghisa; disco di usura in acciaio AISI 316; albero motore in acciaio. Tenuta meccanica in ceramica/grafite. Massima aspirazione: 4 metri. Versione monofase con protezione termica incorporata; versione trifase con protezione a cura dell'utente. Classe di protezione IP 55. Isolamento classe F. Massima temperatura del liquido pompato: 80 °C.

Queste pompe possono essere fornite anche con motori benzina o diesel.

-  Self-priming pumps with open impeller and inspection cover. Clapper check valve on the inlet. Suitable for the drainage of dirty waters containing solid parts. Pump body, support and impeller in cast-iron; wear disk in stainless steel AISI 316; motor shaft in stainless steel. Mechanical seal in ceramic/graphite. Max suction: 4 metres. Single-phase voltage pumps with built-in motor protector; the three-phase pumps must be protected by a fused remote isolator switch. Protection class IP 55. Insulation class F. Max temperature of pumped liquid 176 °F (80 °C).

These pumps can be supplied also with petrol or diesel motor.

-  Pompes autoamorçantes avec roue de type ouvert et porte d'inspection. Vanne à clapet dans l'aspiration. Peuvent être utilisées pour drainages des eaux chargées avec corps solides. Corps de pompe et roue en fonte; plat d'usure en acier inox AISI 316; arbre moteur en acier inox. Garniture mécanique en céramique/graphite. Aspiration jusqu'à 4 mètres de profondeur. Bobinage monophasé avec protection thermique incorporée; bobinage triphasé avec protection par l'utilisateur. Protection IP55. Isolation classe F. Température max. de l'eau pompée: 80 °C.

On peut livrer aussi des modèles avec moteur à essence ou diesel.

-  Selbstansaugende Pumpen mit offenes Laufrad und Inspektionstür. Clapet Ventil auf der Saug-Seite. Geeignet zur Drainage von Schmutzwasser mit Festkörper. Pumpengehäuse und Laufrad aus Grauguss; Verschleißscheibe aus rostfreiem Stahl AISI 316; Antriebswelle aus rostfreiem Stahl. Gleitringdichtung aus Keramik/Graphit. Manometrische Saughöhe: 4 Meter.

Einphasenspannung mit thermischen Motorschutz. Dreiphasenspannung mit Motorvollschutz nach Benutzersorge. IP55 Schutz. Isol. Klasse F. Max Temperatur der Flüssigkeit: 80 °C.

Auf Wunsch sind Pumpen mit Benzinmotor oder Dieselmotor.

Modello Model Modèle Modell	Potenza Power Puissance Pferdestärke		Tensione Voltage Bobinage Spannung V-Hz-ph	A	Portata - Capacity - Débit - Fördermenge (m ³ /h)							
	HP	kW			6	12	24	36	48	60	84	96
	Prevalenza - Head - Hauteur - Förderhöhe (m)											
SW 200	2,0	1,5	230-50-1	9,3	16	15	8					
			230/400-50-3	7,8/4,5								
SW 300	3,0	2,2	230-50-1	12,0	16	16	13	10	6			
			230/400-50-3	9,9/5,7								
SW 550	5,5	4,0	230/400-50-3	13,0/7,5	17	16	16	15	14	13	10	4
SW 750	7,5	5,5	230/400-50-3	18,2/10,5	20	20	20	19	18	18	14	10

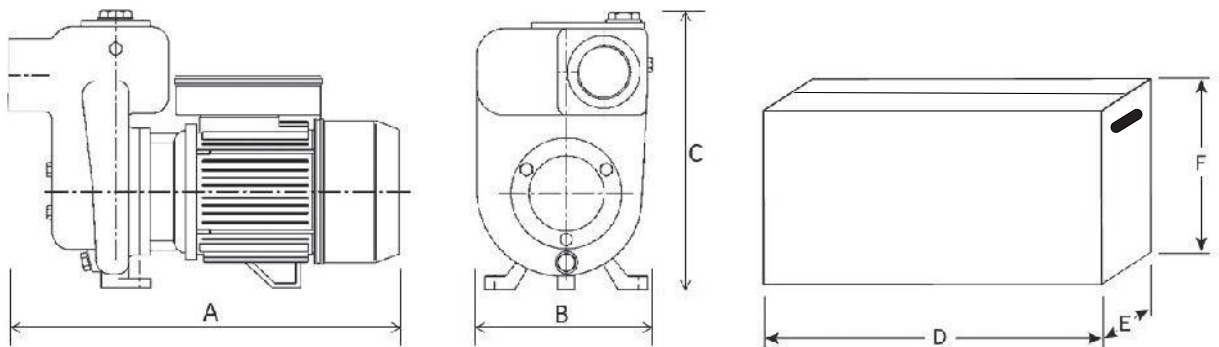
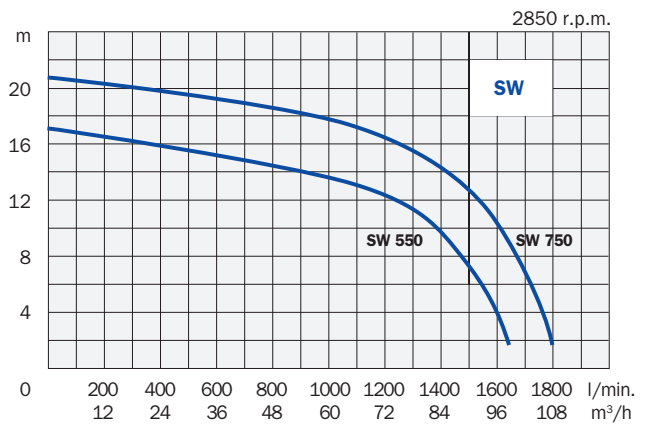
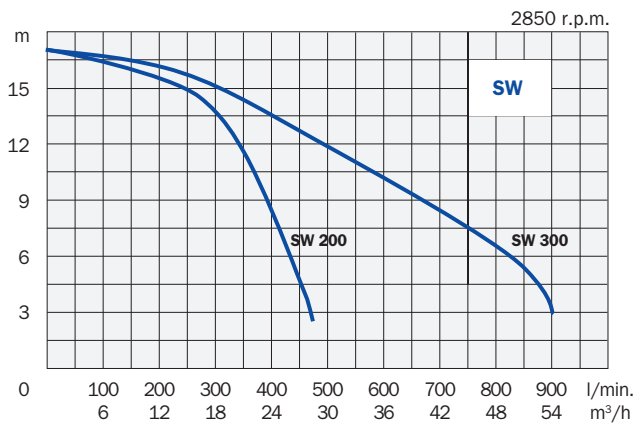

Modello Model Modèle Modell	Aspirazione Suction Aspiration Saug-Seite	Mandata Discharge Refolement Druck-Seite	Corpi solidi Solid parts Corps solides Festkörper mm	Dimensioni - Dimensions - Masstabelle mm						Peso Weight Poids Gewicht kg
				A	B	C	D	E	F	
				SW 200	2"	2"	20	420	215	
SW 300	3"	3"	30	475	245	315	505	295	330	34
SW 550	4"	4"	40	580	370	385	650	500	520	70
SW 750	4"	4"	40	590	370	385	650	500	520	77

POMPE PER GASOLIO

GAS OIL PUMPS



GAS OIL PRO 50

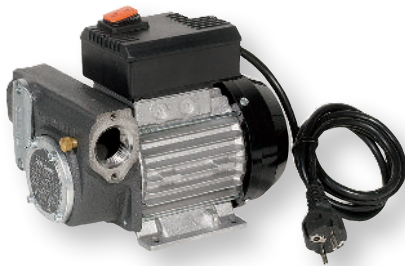

GAS OIL PRO 12V

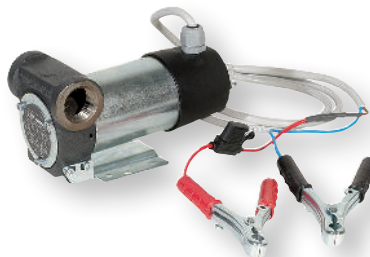

GAS OIL PRO STATION



■ Serie professionale di pompe autoadescanti per gasolio con by-pass incorporato. **GAS OIL PRO 50** con motore a 230V, corpo in ghisa, tenuta meccanica in ceramica, filtro di aspirazione interno, interruttore ON-OFF, cavo di alimentazione con spina "shuko". Aspirazione fino a 4 metri. Protezione IP 55. **GAS OIL PRO 12V** con motore a corrente continua 12V, corpo in ghisa, interruttore ON-OFF, cavo da 2 metri con pinze per il collegamento alla batteria. Per entrambi i modelli è disponibile su richiesta un kit comprendente un tubo di aspirazione in plastica di 4 metri con valvola di fondo ed un tubo di mandata in gomma di 4 metri con pistola manuale (o automatica) in alluminio. Il modello GAS OIL PRO 50 è disponibile anche nella versione **GAS OIL PRO STATION** che comprende il kit di aspirazione/mandata, un supporto in acciaio con conta-litri e porta pistola.

ATTENZIONE: NON USARE PER ACIDI, BENZINA O ALTRI LIQUIDI ESPLOSIVI.

■ Professional series of self-priming pumps for gas oil with built-in by-pass. **GAS OIL PRO 50** with a 230V motor, pump body in cast-iron, mechanical seal in ceramic, internal suction filter, switch ON-OFF, feeding cable with "shuko" plug. Suction head up to 4 metres depth. Protection IP 55. **GAS OIL PRO 12V** with a DC motor, pump body in cast-iron, switch ON-OFF, 2 metres cable with clips for connection to the battery. For both these models it is available on request a kit including a 4 metres suction tube in plastic with foot valve and a 4 metres discharge pipe in rubber with manual (or automatic) pouring off gun in aluminum. The model GAS OIL PRO 50 is available also in the version **GAS OIL PRO STATION** that includes the suction/delivery kit, a stainless steel support with litres-counter and a gun holder.

WARNING: DO NOT USE WITH ACIDS, PETROL OR OTHER EXPLOSIVE LIQUIDS.

■ Pompes autoamorçantes professionnelles pour gasoil avec by-pass incorporé. **GAS OIL PRO 50** avec bobinage 230V, corps de pompe en fonte, garniture mécanique en céramique, filtre d'aspiration, interrupteur ON-OFF, câble d'alimentation avec fiche "shuko". Aspiration jusqu'à 4 mètres de profondeur. Protection IP 55. **GAS OIL PRO 12V** avec moteur à courant continu, corps de pompe en fonte, interrupteur ON-OFF, câble de 2 mètres et pinces à brucelles pour la connexion à la batterie. A la demande on peut livrer un kit avec tuyau d'aspiration en plastique de 4 mètres avec soupape de pied et tuyau de refoulement en gomme de 4 mètres avec pistolet manuel (ou automatique) en aluminium. Le modèle GAS OIL PRO 50 est disponible aussi en version **GAS OIL PRO STATION** avec kit d'aspiration et refoulement, compteur de litres, support en acier et porte pistolet.

ATTENTION: N'EMPLOYEZ PAS CES POMPES NI POUR ESSENCE, NI POUR D'AUTRES LIQUIDES EXPLOSIFS OU CORROSIFS.

■ Selbstansaugende Gasölpumpen mit einem eingebauten Bypass-Ventil. **GAS OIL PRO 50** Einphasenspannung 230V, Pumpengehäuse aus Grauguß, Keramik Gleitringdichtung, Saugfilter, Ein/Ausschalter, Kabel mit Shuko-Stecker. IP 55 Schutz. Manometrische Saughöhe bis zu 4 Meter. **GAS OIL PRO 12V** mit Gleichstrommotor, Pumpengehäuse aus Grauguß, Schalter, Kabel mit Zangen zum Anschluss an die Batterie. Für diese zwei Modellen ist eine Kit lieferbar: Plastiksaugrohr 4M mit Bodenventil und Gummischlauchrohr 4M mit Handpistole (oder automatische Pistolet). **GAS OIL PRO STATION** besteht aus: Pumpe GAS OIL PRO 50, Metallsockel mit Literzähler, Pistolenhalterung und Saug/Auslasskit.

ACHTUNG: NICHT FÜR SÄUREN, BENZIN ODER ANDERE EXPLOSIVE FLÜSSIGKEITEN VERWERDEN.

Modello Model Modèle Modell	Potenza Power Puissance Pferdestärke		Tensione Voltage Bobinage Spannung V-Hz-ph	A	Portata - Capacity - Débit - Fördermenge (l/min)							
	HP	kW			Prevalenza - Head - Hauteur - Förderhöhe (m)							
					0	8	16	24	32	40	48	56
GAS OIL PRO 50	0,5	0,37	230-50-1	3,0	30	29	26	24	20	16	11	4
GAS OIL PRO STATION	0,5	0,37	230-50-1	3,0	30	29	26	24	20	16	11	4
GAS OIL PRO 12V	0,32	0,24	12V	20,0	17	15	14	11	6			

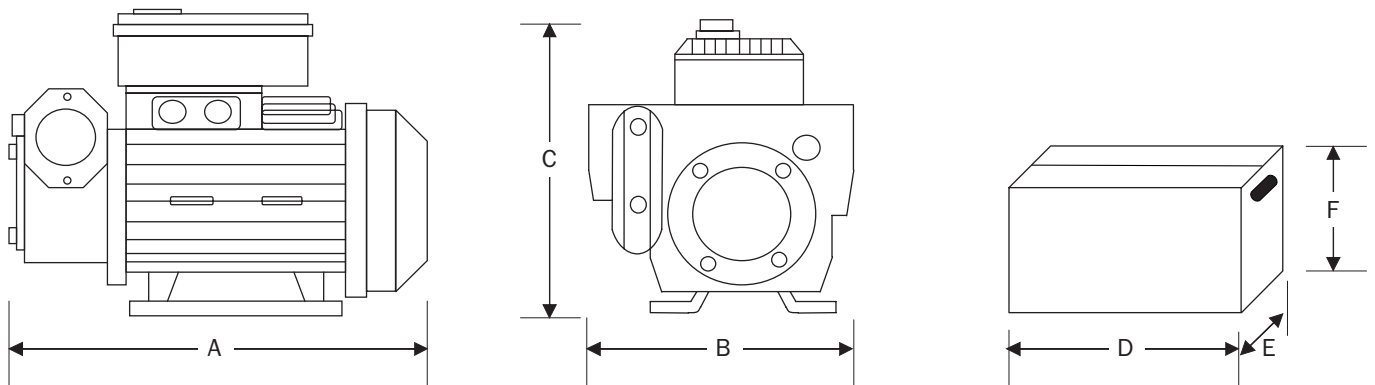
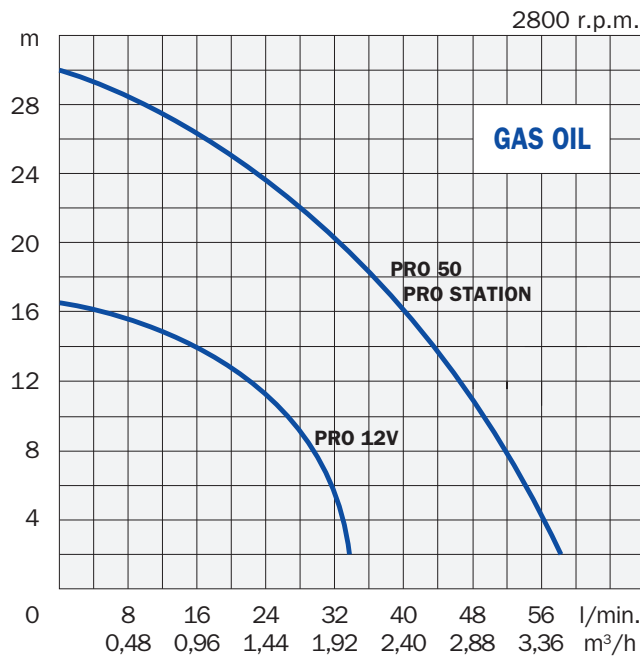

Modello Model Modèle Modell	Aspirazione Suction Aspiration Saug-Seite	Mandata Discharge Refoulement Druck-Seite	Dimensioni Dimensions Masstabelle mm									Peso pompa Pump weight Poids pompe Gewicht Pumpe kg	Peso kit Kit weight Poids kit Gewicht kit kg
			no kit						+ kit				
			A	B	C	D	E	F	D	E	F		
GAS OIL PRO 50	1" - DN 25	1" - DN 25	230	150	170	350	190	270	420	420	310	7,6	6
GAS OIL PRO STATION	1" - DN 25	1" - DN 25	340	260	390	-	-	-	420	420	310	16,5	
GAS OIL PRO 12V	1" - DN 25	1" - DN 25	200	105	115	330	190	160	420	420	310	4,2	6

POMPE PER LIQUIDI ALIMENTARI

FOOD PROCESSING PUMPS

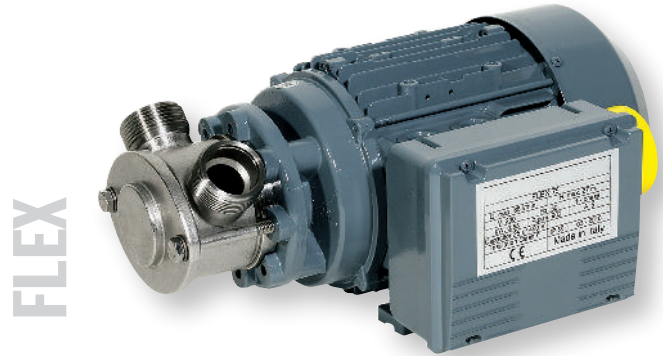
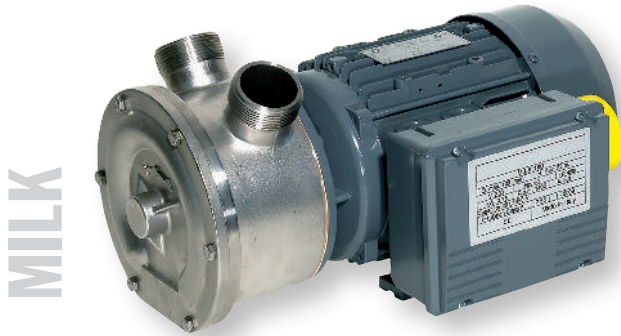

 Pompe autoadescanti a funzionamento reversibile. Corpo pompa ed albero motore in acciaio inox AISI 316. Disponibili con diversi tipi di raccordi e con motore a basso regime di giri per non alterare il liquido pompato.

Le pompe della serie **MILK** hanno una girante stellare in acciaio inox AISI 316 e sono adatte al trasferimento di liquidi alimentari non contenenti particelle solide.

Le pompe della serie **FLEX** hanno una girante flessibile in gomma e sono adatte al pompaggio di una grande varietà di liquidi alimentari anche viscosi o con corpi in sospensione. La girante è disponibile nei seguenti materiali: nitrile, EPDM, neoprene, gomma naturale e silicone. Le giranti in nitrile ed in EPDM sono disponibili anche con certificazione FDA.

Protezione termica incorporata sulle pompe con voltaggio monofase; sui modelli con voltaggio trifase la protezione è a cura dell'utente. Protezione IP 55. Isolamento classe F.

 Self-priming pumps with reversible functioning. Pump body and motor shaft in stainless steel AISI 316. Available with different types of connections and with low number of revolutions per minute motors not to alter the pumped liquid.

The pumps of the series **MILK** have a star type impeller in stainless steel AISI 316 and they are suitable for transferring alimentary liquids without solid parts.

The pumps of the series **FLEX** have a flexible rubber impeller and they are suitable for transferring a wide variety of food liquids also viscous or containing solid parts. The impeller is available in the following materials: nitrile rubber, EPDM, neoprene, natural rubber and silicon. The impellers in nitrile rubber and in EPDM are available also with FDA certification.

Built-in motor protector on single-phase models; the three-phase pumps must be protected by a fused remote isolator switch. Protection class IP 55. Insulation class F.

 Pompes autoamorçantes avec fonctionnement réversible. Corps de pompe et arbre en acier inox AISI 316. Disponibles avec différent types des raccords et avec moteur à bas numéro de tours par minute pour ne pas altérer le liquide pompé.

Les pompes de la série **MILK** ont une roue étoilée en acier inox AISI 316 et sont indiquées pour le transfert de liquides alimentaires sans corps solides.

Les pompes de la série **FLEX** ont une roue flexible en gomme et sont indiquées pour le transfert de liquides alimentaires même visqueux ou contenant des corps en suspension. La roue est disponible en nitrile, EPDM, néoprène, caoutchou et silicone. Les roues en nitrile et en EPDM sont disponibles aussi avec certification FDA.

Protection thermique incorporée sur les modèles avec voltage monophasé; protection par l'installateur sur les modèles triphasés. Protection IP 55. Isolation classe F.

 Selbstansaugende Pumpen mit Wendemotor. Pumpengehäuse und Antriebswelle aus rostfreiem Stahl AISI 316. Lieferbar auch mit Niederturingmotor und mit verschiedenen Typen von Anschlüssen.

Die Pumpen **MILK** haben ein Sternförmige Laufrad aus rostfreiem Stahl AISI 316 und sind geeignet für Nahrungsfüssigkeiten ohne Festkörper. Die Pumpen **FLEX** haben ein Biegarlauftrad aus Gummi und sind geeignet für Nahrungsfüssigkeiten auch dickflüssig. Das Laufrad ist in folgenden Materialien: Nitril, EPDM, Neopren, Naturkautschuk und Silikon. Die Laufräder aus Nitril und aus EPDM sind auch mit FDA Zertifikat lieferbar.

Thermischen Motorschutz bei Pumpen mit Einphasenspannung; Motorschutz nach Benutzersorge bei Pumpen mit Dreiphasenspannung. IP 55 Schutz. Isol. Klasse F.

Modello Model Modèle Modell	Potenza Power Puissance Pferdestärke		Tensione Voltage Bobinage Spannung V-Hz-ph	A	Giri/min. R.p.m. Tours/min U./min	Portata - Capacity - Débit - Fördermenge (l/min)										
	HP	kW				0	10	20	40	60	80	100	120	140	160	200
	Prevalenza - Head - Hauteur - Förderhöhe (m)															
MILK 60	0.6	0.45	230-50-1	4,0	2800	19	15	14	8							
			400-50-3	2,0												
MILK 100	1	0.75	230-50-1	5,3	1400	23	22	21	18	15	12	6				
			400-50-3	2,1												
MILK 200	2	1.5	230-50-1	12,1	1400	30	28	28	27	25	23	21	18	16	12	6
			400-50-3	4,4												
FLEX 50	0.5	0.37	230-50-1	3,7	900	24	13									
			400-50-3	1,1												
FLEX 75	0.75	0.55	230/50/1	5,0	900	27	24	22	16	7						
			400/50/3	1,7												
FLEX 100	1	0.75	230/50/1	7,1	1400	30	29	28	24	18	11	1				
			400/50/3	2,1												

*On request motors with other voltages or at 12V - 24V are available

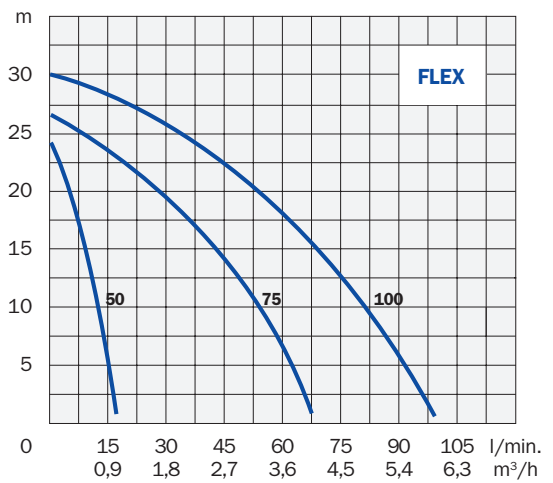
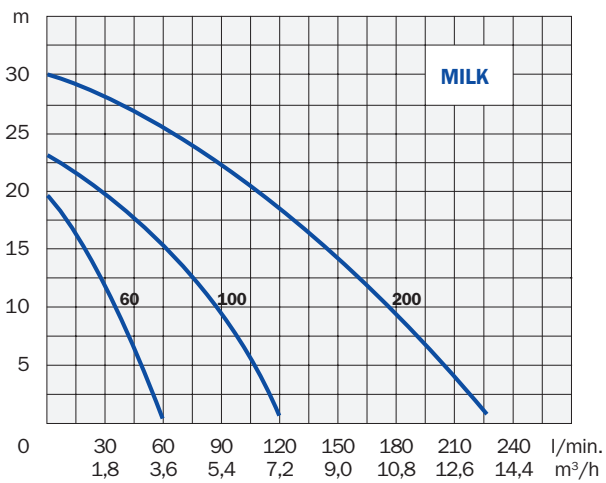

On request bigger models are available

Attention: the performance curves of the FLEX pumps can vary depending on the material of the impeller and the temperature of the liquid pumped

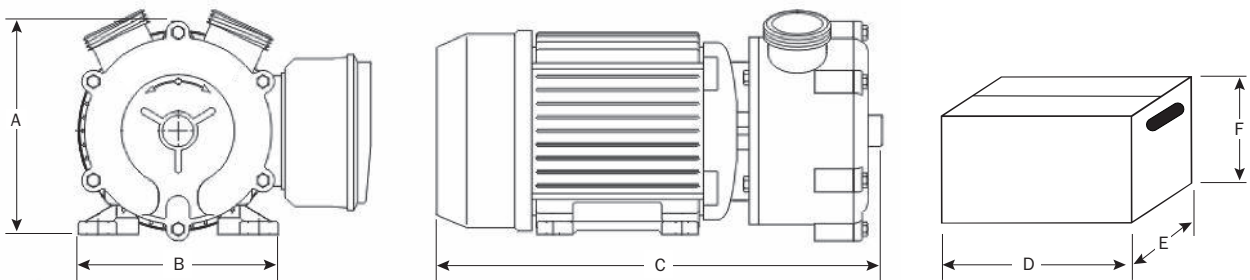

Modello Model Modèle Modell	Aspirazione Suction Aspiration Saug-Seite	Mandata Discharge Refoulement Druck-Seite	Dimensioni - Dimensions - Masstabelle						Peso Weight Poids Gewicht
			mm						
			A	B	C	D	E	F	
MILK 60	1"1/4 M - DN 32	1"1/4 M - DN 32	137	136	336	390	275	270	10
MILK 100	1"1/2 M - DN 40	1"1/2 M - DN 40	165	155	360	390	275	270	16
MILK 200	2" M - DN 50	2" M - DN 50	193	175	440	470	310	290	27
FLEX 50	3/4" M - DN 20	3/4" M - DN 20	140	139	276	390	275	270	10
FLEX 75	1"1/4 M - DN 32	1"1/4 M - DN 32	160	156	338	390	275	270	15
FLEX 100	1"1/4 M - DN 32	1"1/4 M - DN 32	160	159	338	390	275	270	15

POMPE A TRASCINAMENTO MAGNETICO

MAGNETIC DRIVE PUMPS

SERIE MAG



 Pompe a trascinamento magnetico per il trasferimento di acidi, liquidi corrosivi, solventi per la stampa fotografica, liquidi alcalini, acqua salata, ecc.

Corpo pompa e girante in propilene con fibre di vetro. Albero in ceramica. La girante incorpora un magnete. Il magnete di comando dall'esterno del corpo pompa fa ruotare la girante utilizzando il campo magnetico.

Protezione IP 44. Isolamento classe F. Temperatura massima del liquido da pompare 80 °C; massima densità 1100 kg/m³; massima viscosità 30 cPs.

 Magnetic drive pumps for transferring acids, corrosive liquids, solvents for photo printing, alkaline liquids, salted water, etc. Pump body and impeller in propylene reinforced with fibre glass. Shaft in ceramic. The impeller contains a magnet. The leading magnet from outside the pump body creates a magnetic field and it gets the impeller to rotate.

Protection class IP 44. Insulation class F. Max. temperature of pumped liquid 176 °F (80 °C); max. density 1100 kg/m³; max viscosity: 30 cPs.

 Pompes à entraînement magnétique pour le pompage de liquides acides et corrosifs, solvants pour l'impression photographique, bases liquides, eau salée, etc.

Corps de pompe et roue en propylène avec fibre de verre. Arbre en céramique. La roue inclue un aimant. Un entraineur magnétique fixé sur l'axe du moteur transmet le mouvement à l'aimant de la turbine.

Protection IP 44. Isolation classe F. Température max. du liquide pompé 80 °C; densité max. 1100 kg/m³; viscosité max: 30 cPs.

 Magnetgetriebene Kreiselpumpen sind in vielen Anwendungen wie bei chemischen Prozessen, Galvanotechnik, Wasseraufbereitung, Photoentwicklung, usw. zu finden.

Pumpengehäuse und Laufrad aus Propylen mit Nirosta. Antriebswelle aus Keramik. Ein Magnetpaar, welches mit dem Laufrad verbunden ist, treibt die Pumpe an. IP 44 Schutz. Isol. Klasse F. Max. Temperatur der Flüssigkeit 80 °C; max. Dichte 1100 kg/m³, max Viskosität: 30 cPs.

Modello Model Modèle Modell	Potenza Power Puissance Pferdestärke		Tensione Voltage Bobinage Spannung V-Hz-ph	A	Giri/min. R.p.m. Tours/min U./min	Portata - Capacity - Débit - Fördermenge (l/min)					
	HP	W				10	20	30	50	70	90
	Prevalenza - Head - Hauteur - Förderhöhe (m)										
MAG 04	0.04	30	230-50-1	0,1	2800	2,2	1,3				
MAG 08	0.08	60	230-50-1	0,2	2700	3,1	2,5	1,7			
MAG 13	0.13	100	230-50-1	0,6	2850	5,3	5	4,5	2,5		
MAG 20	0.20	150	230-50-1	1,6	2850	7,8	7,5	7,1	6	3,5	
MAG 33	0.33	250	230-50-1	1,8	2850	8,8	8,5	8,1	7	5,6	3,4

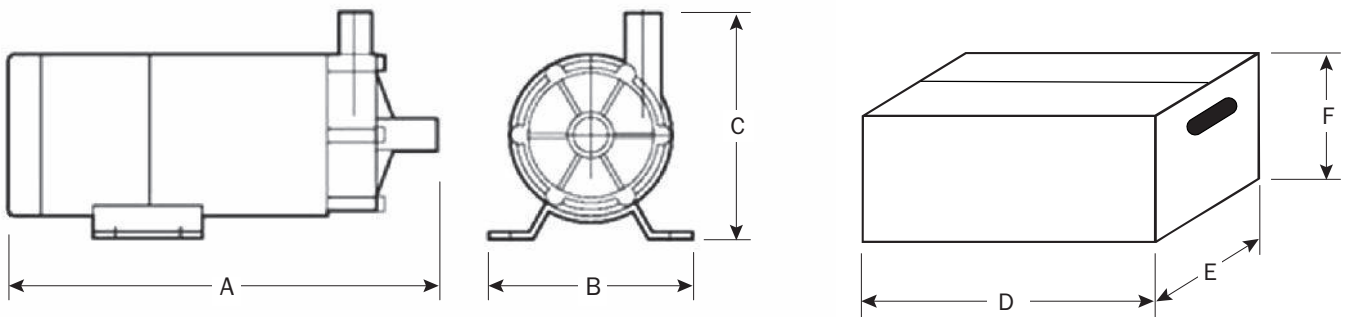
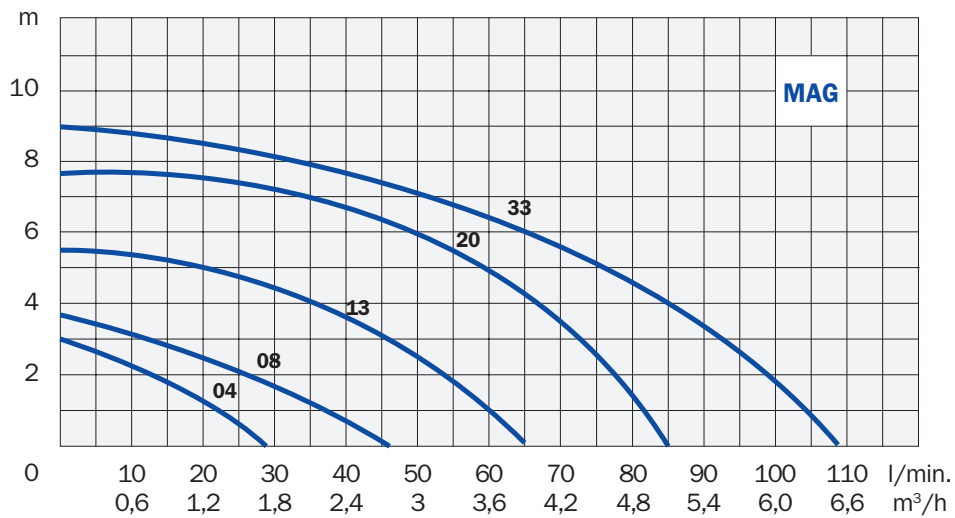

Modello Model Modèle Modell	Aspirazione Suction Aspiration Saug-Seite	Mandata Discharge Refolement Druck-Seite	Dimensioni - Dimensions - Masstabelle						Peso Weight Poids Gewicht kg
			mm						
			A	B	C	D	E	F	
MAG 04	3/4" - DN 20	3/4" - DN 20	181	92	114	230	110	160	2,2
MAG 08	3/4" - DN 20	3/4" - DN 20	206	120	130	325	205	220	3,0
MAG 13	3/4" - DN 20	3/4" - DN 20	272	95	134	320	210	280	3,5
MAG 20	1" - DN 25	1" - DN 25	286	130	160	320	210	280	7,5
MAG 33	1" - DN 25	1" - DN 25	345	156	175	380	220	210	9,5

SOCCORRITORI ANTI-ALLAGAMENTO

EMERGENCY UNITS FOR FLOODING PREVENTION

SOCCORRITORE



-  I SOCCORRITORI anti-allagamento sono prodotti molto affidabili progettati per poter alimentare pompe sommergibili monofasi anche in caso di interruzioni temporanee dell'energia elettrica.
- In presenza di energia elettrica di rete il SOCCORRITORE mantiene in carica le batterie in dotazione; in assenza di energia elettrica di rete converte la tensione delle batterie in tensione alternata ed alimenta la pompa. Il SOCCORRITORE può funzionare sia con batterie al piombo (aperte o sigillate) sia con batterie al gel.
- Il soccorritore può inviare un messaggio GSM all'utente in caso di black-out o di malfunzionamento.

-  The EMERGENCY UNITS are very reliable products that have been projected to supply single-phase submersible pumps even in case of temporary black-outs preventing possible floods.
- In presence of electric net supply the EMERGENCY UNIT keeps the batteries in charge; in case of lack of electric net supply the EMERGENCY UNIT converts the batteries' voltage into alternate current and feeds the pump. The EMERGENCY UNIT can work both with lead batteries (open or closed) and gel batteries.
- The emergency unit can send a GSM message in case of black out or if a malfunction should occur.

CARATTERISTICHE GENERALI - GENERAL CHARACTERISTICS

Tensione di alimentazione - Input voltage	230V / 50Hz / 1-ph
Tensione d'uscita - Output voltage	230V / 50Hz / 1-ph
Forma d'onda - Type of wave	Pseudo-sinusoidale (con funzionamento a batterie) <i>Pseudo-sine (when working with batteries)</i>
Commutazione rete/batterie - Switching line/batteries	Automatica (1 secondo) - <i>Automatic (1 second)</i>
Corrente carica batterie - Batteries' charging current	Circa 3A - <i>About 3A</i>

SCelta MODELLO – MODEL CHOICE	1000-D	1500-D	2000-D	3000-D	4000-D
Massima superficie scoperta (m²) <i>Max open air surface (m²)</i>	55	80	110	180	230
Autonomia funzionamento con batterie <i>Working time with batteries</i>	100 min	180 min	90 min	80 min	80 min
Pompa COMEX generalmente abbinata <i>COMEX pump generally combined</i>	VORTEX 50	VORTEX 75	VORTEX 100	VORTEX 150	VORTEX 200

DATI TECNICI – TECHNICAL DATA	1000-D	1500-D	2000-D	3000-D	4000-D
Potenza nominale <i>Nominal power</i>	900 VA	1300 VA	2100 VA	3100 VA	4100 VA
N° batterie <i>Number of batteries</i>	N° 2 x 12V - 105Ah	N° 2 x 12V - 180Ah	N° 3 x 12V - 180Ah	N° 3 x 12V - 180Ah	N° 3 x 12V - 180Ah
Tensione dalle batterie <i>Voltage from batteries</i>	24 Vcc	24 Vcc	36 Vcc	36 Vcc	36 Vcc
Limite minima tensione dalle batterie <i>Min voltage from batteries</i>	20 Vcc	20 Vcc	30 Vcc	30 Vcc	30 Vcc
Max corrente assorbita dalla pompa <i>Max current absorbed by pump</i>	3,1 A	6,1 A	7,7 A	11,8 A	15,6 A

DIMENSIONI – DIMENSIONS	1000-D	1500-D	2000-D	3000-D	4000-D
Larghezza – Width (mm)	400	400	400	400	400
Profondità – Length (mm)	220	220	220	220	220
Altezza – Height (mm)	500	500	500	500	500
Peso – Weight (kg)	19	25	26	32	38

Optional:

MODULO SCAMBIATORE EXCHANGER BOARD
<p>In caso di installazione di due pompe, lo scambiatore permette il funzionamento alternato delle due pompe ed in caso di necessità si avvia anche la seconda pompa assieme alla prima. In mancanza di energia elettrica di rete funziona solo una pompa.</p> <p><i>In case of installation of two pumps, the exchanger board alternates the working of the two pumps and, in case of need, both pumps work together.</i> <i>In case of lack of electrical connection only one pump works</i></p>

SIRENA D'ALLARME ALARM HORN
<p>Sirena autoalimentata, con autonomia di 24 ore. L'allarme si attiva quando il galleggiante della sirena si alza oppure quando la sirena riceve un segnale di malfunzionamento dal SOCCORRITORE.</p> <p><i>Alarm horn board with 24 hours battery life. The horn starts when the alarm float-switch goes up or when the alarm receives a warning message from the EMERGENCY UNIT.</i></p>

QUADRI ELETTRICI CONTROL BOXES



SERIE L1 - SERIES L1

Piccolo control box in PVC per una pompa monofase fino a 2HP. Include un disgiuntore magnetotermico, un condensatore ed un interruttore ON-OFF. IP55.

Small control box in PVC for a single-phase pump up to 1.5kW. It includes a thermal-magnetic cut-out, a capacitor and an ON-OFF switch. IP 55.

SERIE F5 / F6 - SERIES F5 / F6

Aviatore diretto elettronico in ABS per una pompa monofase (modello F5) fino a 3HP o trifase (modello F6) fino a 10HP. Ingresso in bassa tensione per galleggiante o pressostato, ingresso per sondine di livello. Protegge la pompa da assorbimento eccessivo (valore regolabile), da mancanza di fase e inversione di fasi (solo F6). Disponibile con kit GSM per controllo remoto. IP55.

Electronic direct starter in ABS for a single-phase pump (model F5) up to 2.2kW or three-phase pump (model F6) up to 7.5kW. Low voltage input for float-switch or pressure switch, input for level probes. It protects the pump against too high absorption (adjustable value), lack of one phase and wrong sequence of phases (only F6). Available with GSM kit for remote control. IP55.



SERIE F1 - SERIES F1

Aviatore diretto elettromeccanico in metallo per una pompa monofase fino a 3HP o trifase fino a 50HP. Ingresso in bassa tensione per galleggiante o pressostato. Protegge la pompa da assorbimento eccessivo (valore regolabile), da mancanza di fase e inversione di fasi. Disponibile con voltmetro ed amperometro. Disponibile anche con kit GSM per controllo remoto. IP55.

Electromechanical direct starter in metal for a single-phase pump up to 2.2kW or three-phase pump up to 37kW. Low voltage input for float-switch or pressure switch. It protects the pump against too high absorption (adjustable value), lack of one phase and wrong sequence of phases. Available with voltmeter and ammeter. Available also with GSM kit for remote control. IP55.

SERIE F5(2) / F6(2) - SERIES F5(2) / F6(2)

Aviatore diretto elettronico in ABS per due pompe monofasi (modello F5(2)) fino a 3HP o trifasi (modello F6(2)) fino a 10HP. Ingresso in bassa tensione per due galleggianti o due pressostati. Il quadro alterna le due pompe ed in caso di necessità le fa funzionare contemporaneamente. Protegge le pompe da assorbimento eccessivo (valore regolabile). Disponibile con kit GSM per controllo remoto. IP55.

Electronic direct starter in ABS for two single-phase pumps (model F5(2)) up to 2.2kW or two three-phase pumps (model F6(2)) up to 7.5kW. Low voltage input for two float-switches or pressure switches. The starter alternates the two pumps and in case of need both pumps work together. It protects the pumps against too high absorption (adjustable value). Available with GSM kit for remote control. IP55.



SERIE INV-EASY - SERIES INV-EASY

Inverter regolatore di frequenza in ABS. Serie MT: ingresso alimentazione 230/50/1, uscita 230/50/3; serie TT: ingresso alimentazione 400/50/3, uscita 400/50/3. La pressione dell'impianto viene rilevata tramite un trasduttore di pressione. L'inverter aumenta o diminuisce il numero di giri del motore per mantenere la pressione stabilita al variare della portata richiesta. IP54.

Frequency converter in ABS. Series MT: inlet 230/50/1, outlet 230/50/3; serie TT: inlet 400/50/3, outlet 400/50/3. The pressure on the plant is measured through a pressure probe. The converter increases or reduces the turns per minute of the motor in order to keep the set pressure in spite the capacity required varies. IP54.

ALLARME - ALARM BOARD

Sirena autoalimentata con batteria tampone della durata di circa 24 ore. L'allarme si attiva al sollevarsi del galleggiante collegato al quadro. Disponibile anche con avvisatore luminoso e con kit GSM per controllo remoto. IP55.

Alarm horn with 24 hours autonomy battery. The horn starts when the float-switch connected to the electric board rises. Available also with flashing light and with GSM kit for remote control. IP55.





Autoclavi con vaso orizzontale

Pressure systems with horizontal tank



Autoclavi con vaso sferico

Pressure systems with spherical tank



Autoclavi con PRESSCONTROL

Pressure systems with PRESSCONTROL



Miscelatori sommersi

Submersible mixers



Pompe idrauliche

Hydraulic engine pumps



Vasi verticali ed orizzontali da 24L a 500L

Vertical and horizontal pressure tanks from 24 to 500 litres



Conessioni "storz"

"Storz" connections



Manichette appiattibili

Flat PVC hoses



Valvole di non ritorno a palla per acque cariche

Ball check valves for sewage water



Giunzioni cavi affogate in resina

Resin kit for cable junction

I dati tecnici non sono impegnativi.
COMEX si riserva il diritto di apportare
modifiche senza preavviso.

Technical data are not binding.
COMEX reserves the right of making
modifications without prior notice.



COMEX S.r.l.

Società Unipersonale

**Via delle Industrie, 42
31057 SILEA (TREVISO) - Italy**

Tel. +39 0422.362215

E-mail: info@comexpumps.com

<http://www.comexpumps.com>