

**Models** GRINDER 200 / 23 MG  
GRINDER 200 / 23 M

**Description** Professional grinding pump suitable to chop up diapers, paper, nylon bags, rags, latex gloves, etc. Its most frequent applications are in the pumping of sewage water in hotels, camping sites, restaurants and hospitals. In general grinding pumps are necessary when the discharge pipe is narrow or when a high head is required. The single-phase models are supplied with an external control box (at the end of the feeding cable) including a starting capacitor to increase the starting torque and an amperometric protection at manual reset.



**Pumped fluid** Sewage water containing solid parts  
**Application**  
**Max Density** 1100 kg/m<sup>3</sup>  
**Temperature range** 0-40 °C 32-104 °F  
**pH range** 6-10 pH

**Performance**

Models		Head (m)						
		0	4	8	12	16	20	24
		<b>Capacity</b>						
GRINDER 200 / 23 MG	l/min	170	169	167	158	134	98	50
GRINDER 200 / 23 M	m <sup>3</sup> /h	10,2	10,1	10,0	9,5	8,0	5,9	3,0
	l/s	2,83	2,82	2,78	2,63	2,23	1,63	0,83

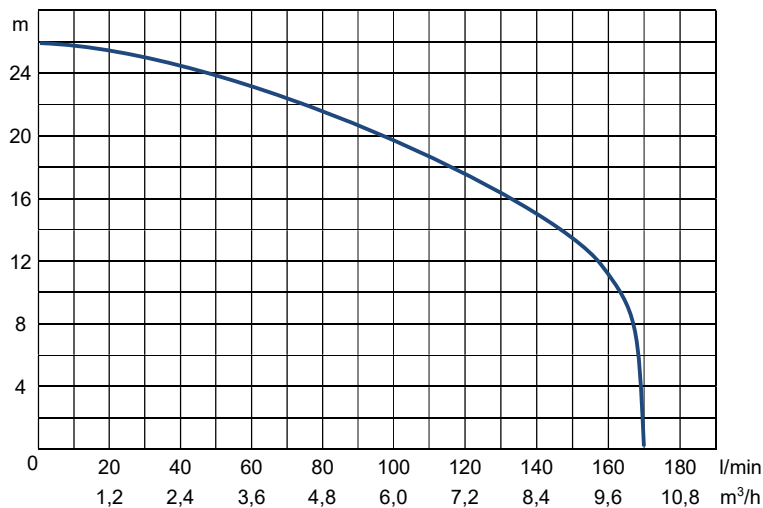

**Hydraulic**

<i>Impeller type</i>	Multi-channel open impeller type
<i>Outlet</i>	DN 50 – vertical, PN 10, oval counter-flange threaded 2” BSP
<i>Free passage</i>	-
<i>Max head</i>	26 m (2.6 bar)
<i>Min head</i>	0 m
<i>Max capacity</i>	170 l/min
<i>Min suction level</i>	230 mm

**Electric characteristics**

Models	Power (P <sub>2</sub> )		rpm	Voltage V	ph	I <sub>N</sub> A	Built-in float-switch	Capacitor μF
	HP	kW						
GRINDER 200 / 23 MG	2.0	1.5	2850	230	1~	12,9	YES	30 <sup>(1)</sup> + 100 <sup>(2)</sup>
GRINDER 200 / 23 M							NO	

(1) Running capacitor inside the pump

(2) Starting capacitor into the external control box

**Technical characteristics**

<i>IP</i>	68
<i>Sealing</i>	Double mechanical seal in oil bath + oil seal
<i>Max. immersion</i>	5 meters (with 10 meters cable)
<i>Protective coating</i>	Two-component epoxy paint anti-corrosion
<i>Sound pressure level</i>	< 70dB

**Components & Materials**

<i>Cable</i>	Neoprene H07RNF length 10 meters 4G1,5 + Control box + Neoprene H07RNF length 1,5 meters 3G1,5 with molded SHUKO plug
<i>Cutting system</i>	Stainless steel AISI 440 1.4112
<i>Impeller</i>	Cast-iron EN-GJL-250
<i>Pump support</i>	Cast-iron EN-GJL-250
<i>Discharge body</i>	Cast-iron EN-GJL-250
<i>Motor case</i>	Cast-iron EN-GJL-250
<i>Pump cover</i>	Cast-iron EN-GJL-250
<i>Motor shaft</i>	Stainless steel AISI 420B 1.4028
<i>Screws</i>	Stainless steel AISI 304 1.4301 (A2)
<i>Mechanical seal</i>	Lower: Silicon carbide / Silicon carbide / NBR / AISI 304 Upper: Silicon carbide / Silicon carbide / NBR / AISI 304
<i>Oil seal</i>	NBR
<i>Kit o-ring</i>	NBR
<i>Ball bearings</i>	Lower: 6305 RZ, upper: 6205 RZ
<i>Oil</i>	Dielectric, not polluting, not toxic

**Motor characteristics**

Type of motor	Hard-duty squirrel cage motor
Start type	DOL (Direct On Line)
Protection	Built-in automatic-reset thermal-amperometric protection + manual-reset amperometric protection on the external control box.
Insulation class	Class F
Nos. of poles	2
Service type	S2
Cooling	Ensured by the immersion of the pump into the fluid

**Optional available**

Coupling foot	Coupling foot model 2" vertical (connection 2")
Hose connection	Straight hose connection in brass, 3 pieces, 2" x DN50mm
Electric board	F5-0.5/3-1 (only for model without float-switch)
No return valve	Professional no-return ball check valve 2" in cast-iron with NBR ball
Separated float switch	10 meters cable or 20 meters cable float-switch to be connected to an electric board F5-0.5/3-1
Anods	To avoid corrosion by galvanic currents

**Dimensions & weight**

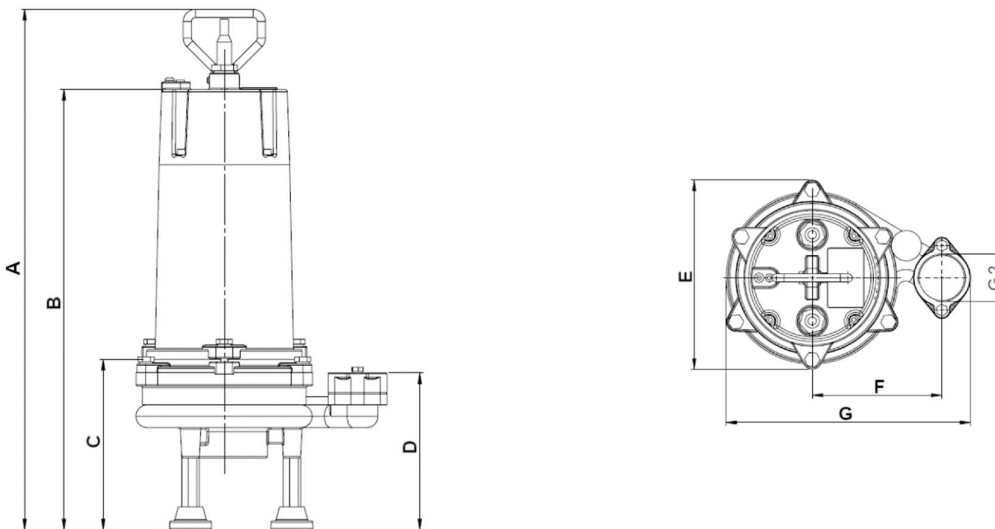

Models	Dimensions (mm)							Carton box	Weight kg	Pumps per layer on EPAL
	A	B	C	D	E	F	G			
GRINDER 200 / 23 MG	637	539	209	192	237	163	307	295x255xH770	44	12
GRINDER 200 / 23 M										