

Models GRINDER 200 / 23 T
GRINDER 300 / 23 T

Description Professional grinding pump suitable to chop up diapers, paper, nylon bags, rags, latex gloves, etc. Its most frequent applications are in the pumping of sewage water in hotels, camping sites, restaurants and hospitals. In general grinding pumps are necessary when the discharge pipe is narrow or when a high head is required.



Pumped fluid Sewage water containing solid parts
Application
Max Density 1100 kg/m³
Temperature range 0-40 °C 32-104 °F
pH range 6-10 pH

Performance

Models		Head (m)						
		4	8	12	16	20	24	28
		Capacity						
GRINDER 200 / 23 T	l/min	169	167	158	134	98	50	
	m ³ /h	10,1	10,0	9,5	8,0	5,9	3,0	
	l/s	2,82	2,78	2,63	2,23	1,63	0,83	
GRINDER 300 / 23 T	l/min	170	169	168	164	149	118	75
	m ³ /h	10,2	10,1	10,1	9,8	8,9	7,1	4,5
	l/s	2,83	2,82	2,80	2,73	2,48	1,97	1,25

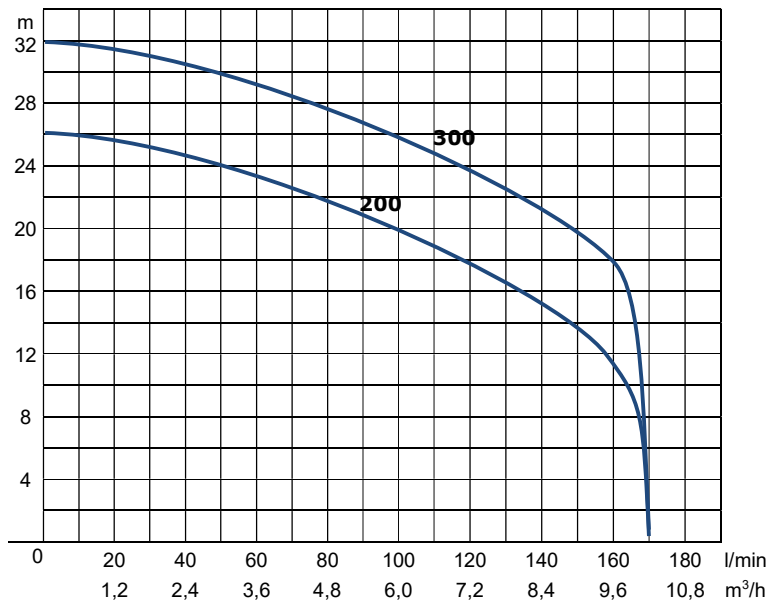

Hydraulic

<i>Impeller type</i>	Multi-channel open impeller type
<i>Outlet</i>	DN 50 – vertical, PN 10, oval counter-flange threaded 2” BSP
<i>Free passage</i>	-
<i>Max head</i>	GRINDER 200 / 23 T: 26m (2.6 bar) GRINDER 300 / 23 T: 32m (3.2 bar)
<i>Min head</i>	0 m
<i>Max capacity</i>	170 l/min
<i>Min suction level</i>	230 mm

Electric characteristics

Models	Power (P₂)		rpm	Voltage	ph	I_N	Built-in float-switch
	HP	kW					
GRINDER 200 / 23 T	2.0	1.5	2850	400	3~	4,3	NO
GRINDER 300 / 23 T	3.0	2.2					

Technical characteristics

<i>IP</i>	68
<i>Sealing</i>	Double mechanical seal in oil bath + oil seal
<i>Max. immersion</i>	5 meters (with 10 meters cable)
<i>Protective coating</i>	Two-component epoxy paint anti-corrosion
<i>Sound pressure level</i>	< 70dB

Components & Materials

<i>Cable</i>	Neoprene H07RNF length 10 meters 4G1,5 with free ends
<i>Cutting system</i>	Stainless steel AISI 440 1.4112
<i>Impeller</i>	Cast-iron EN-GJL-250
<i>Pump support</i>	Cast-iron EN-GJL-250
<i>Discharge body</i>	Cast-iron EN-GJL-250
<i>Motor case</i>	Cast-iron EN-GJL-250
<i>Pump cover</i>	Cast-iron EN-GJL-250
<i>Motor shaft</i>	Stainless steel AISI 420B 1.4028
<i>Screws</i>	Stainless steel AISI 304 1.4301 (A2)
<i>Mechanical seal</i>	Lower: Silicon carbide / Silicon carbide / NBR / AISI 304 Upper: Silicon carbide / Silicon carbide / NBR / AISI 304
<i>Oil seal</i>	NBR
<i>Kit o-ring</i>	NBR
<i>Ball bearings</i>	Lower: 6305 RZ, upper: 6205 RZ
<i>Oil</i>	Dielectric, not polluting, not toxic

Motor characteristics

Type of motor	Hard-duty squirrel cage motor
Start type	DOL (Direct On Line)
Protection	By a magnetothermic switch by the user (see optional section for electric boards)
Insulation class	Class F
Nos. of poles	2
Service type	S2
Cooling	Ensured by the immersion of the pump into the fluid

Optional available

Coupling foot	Coupling foot model 2" vertical (connection 2")
Hose connection	Straight hose connection in brass, 3 pieces, 2" x DN50mm
Electric board	F6-0.5/10-3 (strongly recommended)
No return valve	Professional no-return ball check valve 2" in cast-iron with NBR ball
Separated float switch	10 meters cable or 20 meters cable float-switch to be connected to an electric board F6-0.5/10-3
Anods	To avoid corrosion by galvanic currents

Dimensions & weight

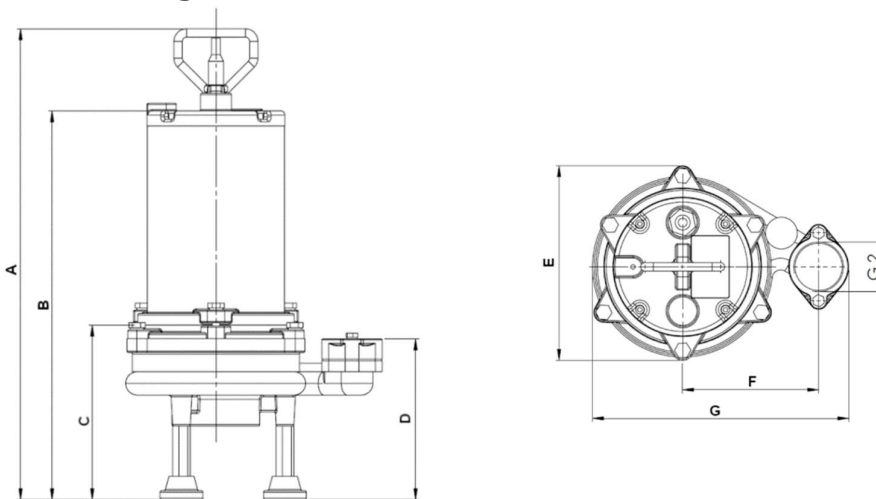

Models	Dimensions (mm)							Carton box	Weight kg	Pumps per layer on EPAL
	A	B	C	D	E	F	G			
GRINDER 200 / 23 T	563	465	209	192	233	163	307	295x255xH550	42	12
GRINDER 300 / 23 T									43	