

# POMPE PER GASOLIO

## GAS OIL PUMPS



GAS OIL PRO 50



GAS OIL PRO 12V



GAS OIL PRO STATION



■ Serie professionale di pompe autoadescanti per gasolio con by-pass incorporato. **GAS OIL PRO 50** con motore a 230V, corpo in ghisa, tenuta meccanica in ceramica, filtro di aspirazione interno, interruttore ON-OFF, cavo di alimentazione con spina "shuko". Aspirazione fino a 4 metri. Protezione IP 55. **GAS OIL PRO 12V** con motore a corrente continua 12V, corpo in ghisa, interruttore ON-OFF, cavo da 2 metri con pinze per il collegamento alla batteria. Per entrambi i modelli è disponibile su richiesta un kit comprendente un tubo di aspirazione in plastica di 4 metri con valvola di fondo ed un tubo di mandata in gomma di 4 metri con pistola manuale (o automatica) in alluminio. Il modello GAS OIL PRO 50 è disponibile anche nella versione **GAS OIL PRO STATION** che comprende il kit di aspirazione/mandata, un supporto in acciaio con conta-litri e porta pistola.

ATTENZIONE: NON USARE PER ACIDI, BENZINA O ALTRI LIQUIDI ESPLOSIVI.



Professional series of self-priming pumps for gas oil with built-in by-pass. **GAS OIL PRO 50** with a 230V motor, pump body in cast-iron, mechanical seal in ceramic, internal suction filter, switch ON-OFF, feeding cable with "shuko" plug. Suction head up to 4 metres depth. Protection IP 55. **GAS OIL PRO 12V** with a DC motor, pump body in cast-iron, switch ON-OFF, 2 metres cable with clips for connection to the battery. For both these models it is available on request a kit including a 4 metres suction tube in plastic with foot valve and a 4 metres discharge pipe in rubber with manual (or automatic) pouring off gun in aluminum. The model GAS OIL PRO 50 is available also in the version **GAS OIL PRO STATION** that includes the suction/delivery kit, a stainless steel support with litres-counter and a gun holder.

WARNING: DO NOT USE WITH ACIDS, PETROL OR OTHER EXPLOSIVE LIQUIDS.



Pompes autoamorçantes professionnelles pour gasoil avec by-pass incorporé. **GAS OIL PRO 50** avec bobinage 230V, corps de pompe en fonte, garniture mécanique en céramique, filtre d'aspiration, interrupteur ON-OFF, câble d'alimentation avec fiche "shuko". Aspiration jusqu'à 4 mètres de profondeur. Protection IP 55. **GAS OIL PRO 12V** avec moteur à courant continu, corps de pompe en fonte, interrupteur ON-OFF, câble de 2 mètres et pinces à brucelles pour la connexion à la batterie. A la demande on peut livrer un kit avec tuyau d'aspiration en plastique de 4 mètres avec soupape de pied et tuyau de refoulement en gomme de 4 mètres avec pistolet manuel (ou automatique) en aluminium. Le modèle GAS OIL PRO 50 est disponible aussi en version **GAS OIL PRO STATION** avec kit d'aspiration et refoulement, compteur de litres, support en acier et porte pistolet.

ATTENTION: N'EMPLOYEZ PAS CES POMPES NI POUR ESSENCE, NI POUR D'AUTRES LIQUIDES EXPLOSIFS OU CORROSIFS.



Selbstansaugende Gasölpumpen mit einem eingebauten Bypass-Ventil. **GAS OIL PRO 50** Einphasenspannung 230V, Pumpengehäuse aus Grauguß, Keramik Gleitringdichtung, Saugfilter, Ein/Ausschalter, Kabel mit Shuko-Stecker. IP 55 Schutz. Manometrische Saughöhe bis zu 4 Meter. **GAS OIL PRO 12V** mit Gleichstrommotor, Pumpengehäuse aus Grauguß, Schalter, Kabel mit Zangen zum Anschluss an die Batterie. Für diese zwei Modellen ist eine Kit lieferbar: Plastiksaugrohr 4M mit Bodenventil und Gummischauslassrohr 4M mit Handpistole (oder automatische Pistolet). **GAS OIL PRO STATION** besteht aus: Pumpe GAS OIL PRO 50, Metallsockel mit Literzähler, Pistolenhalterung und Saug/Auslasskit.

ACHTUNG: NICHT FÜR SÄUREN, BENZIN ODER ANDERE EXPLOSIVE FLÜSSIGKEITEN VERWERDEN.

Modello Model Modèle Modell	Potenza Power Puissance Pferdestärke		Tensione Voltage Bobinage Spannung V-Hz-ph	A	Portata - Capacity - Débit - Fördermenge (l/min)							
	HP	kW			0	8	16	24	32	40	48	56
	Prevalenza - Head - Hauteur - Förderhöhe (m)											
<b>GAS OIL PRO 50</b>	0,5	0,37	230-50-1	3,0	30	29	26	24	20	16	11	4
<b>GAS OIL PRO STATION</b>	0,5	0,37	230-50-1	3,0	30	29	26	24	20	16	11	4
<b>GAS OIL PRO 12V</b>	0,32	0,24	12V	20,0	17	15	14	11	6			

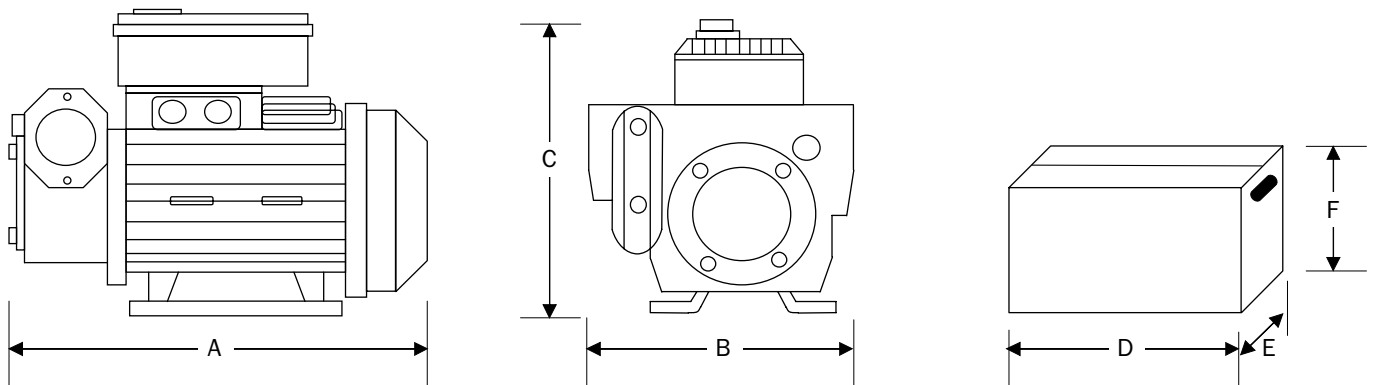
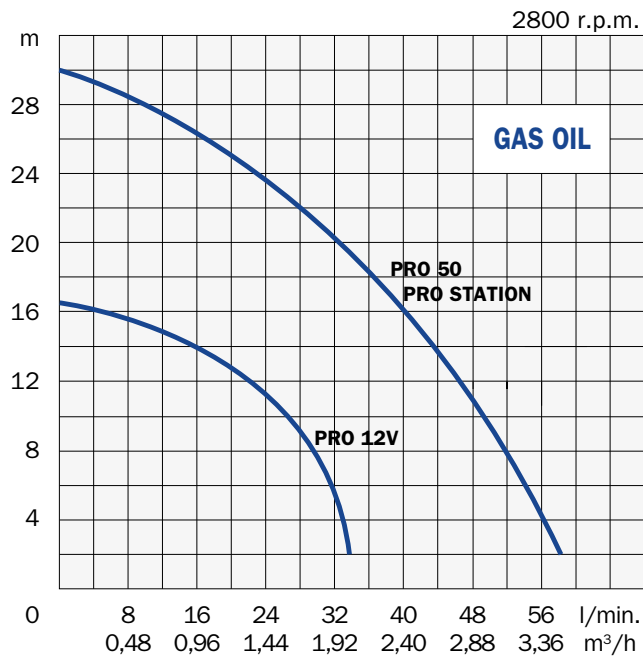

Modello Model Modèle Modell	Aspirazione Suction Aspiration Saug-Seite	Mandata Discharge Refoulement Druck-Seite	Dimensioni Dimensions Masstabelle mm									Peso pompa Pump weight Poids pompe Gewicht Pumpe kg	Peso kit Kit weight Poids kit Gewicht kit kg
			no kit						+ kit				
			A	B	C	D	E	F	D	E	F		
<b>GAS OIL PRO 50</b>	1" - DN 25	1" - DN 25	230	150	170	350	190	270	420	420	310	7,6	6
<b>GAS OIL PRO STATION</b>	1" - DN 25	1" - DN 25	340	260	390	-	-	-	420	420	310	16,5	
<b>GAS OIL PRO 12V</b>	1" - DN 25	1" - DN 25	200	105	115	330	190	160	420	420	310	4,2	6