

# POMPE CENTRIFUGHE BIGIRANTI

## TWO-STAGES CENTRIFUGAL PUMPS

SERIE 2C



 Pompe bigiranti particolarmente adatte per la distribuzione d'acqua negli impianti domestici. Si prestano bene anche alla distribuzione d'acqua a mezzo di gruppi di pressurizzazione. Robusta costruzione. Alto rendimento. Aspirazione fino a 3 metri. Corpo pompa in ghisa. Giranti in ottone. Tenuta meccanica in ceramica/grafite. Motore chiuso autoventilato. Albero in acciaio inox AISI 304.

Tensione monofase con protezione termica incorporata; tensione trifase con protezione a cura dell'utente.  
Protezione IP 44. Isolamento classe F. Temperatura massima dell'acqua da pompare 70 °C.

 Two-stages pumps suitable for the raising and the distribution of water in houses, hotels and farms. They are also suitable for the distribution of water by means of pressure systems. Heavy duty construction. High performance. Suction head up to 3 metres depth.

Pump body in cast iron. Impellers in brass. Mechanical seal in ceramic/carbon. Closed self-ventilated motor. Shaft in stainless steel AISI 304.

Single-phase voltage with built-in motor protector. The three-phase pumps must be protected by a fused remote isolator switch.  
Protection class IP 44. Insulation class F. Max. temperature of pumped water 158 °F (70 °C).

 Pompes à deux roues indiquées pour la distribution d'eau dans les installations domestiques. Elles sont conseillées aussi pour la distribution automatique d'eau au moyen de groupes hydrophores. Construction robuste. Rendement élevé. Aspiration jusqu'à 3 mètres de profondeur.

Corps de pompe en fonte. Roues en laiton. Garniture mécanique en céramique/graphite. Moteur enfermé avec ventilation extérieure. Arbre en acier inox AISI 304.

Bobinage monophasé avec protection thermique incorporée; bobinage triphasé avec protection par l'utilisateur.  
Protection IP 44. Isolation classe F. Température max. de l'eau pompée 70 °C.

 Zweirad-Pumpen zur Haushaltenanlagen und zur Bewässerungen von Gemüse- und Ziegärten. Höchste Leistungskraft. Sicher im Betrieb. Hergestellt aus hochwertigen Rohstoffen. Manometrische Saughöhe bis zu 3 Meter.

Pumpengehäuse aus Grauguß. Laufräder aus Messing. Keramik/Graphit Gleitringdichtung. Antriebswelle aus rostfreiem Stahl AISI 304.

Einphasenspannung mit thermischen Motorschutz; Dreiphasenspannung mit Motorvollschutz nach Benutzersorge.  
IP 44 Schutz. Isol. Klasse F. Max. Temperatur der Flüssigkeit: 70 °C.

Modello Model Modèle Modell	Potenza Power Puissance Pferdestärke		Tensione Voltage Bobinage Spannung V-Hz-ph	A	Portata - Capacity - Débit - Fördermenge (l/min)						
	HP	kW			0	30	60	90	120	150	180
	Prevalenza - Head - Hauteur - Förderhöhe (m)										
<b>2C 100</b>	1	0,75	230-50-1	5,2	42	35	26				
			230/400-50-3	3,2/1,8							
<b>2C 150</b>	1,5	1,1	230-50-1	8,0	51	47	40	30			
			230/400-50-3	4,8/3,0							
<b>2C 200</b>	2	1,5	230-50-1	11,5	60	57	52	43			
			230/400-50-3	6,4/3,8							
<b>2C 300</b>	3	2,2	230/400-50-3	9,2/5,2	67	64	60	54	44		
<b>2C 400</b>	4	3	230/400-50-3	14,0/8,0	72	71	68	63	55	45	
<b>2C 550</b>	5,5	4	230/400-50-3	17,0/10,0	81	79	76	72	65	55	
<b>2C 750</b>	7,5	5,5	230/400-50-3	20,0/11,5	90	88	85	80	73	64 50	

\*On request other voltages are available

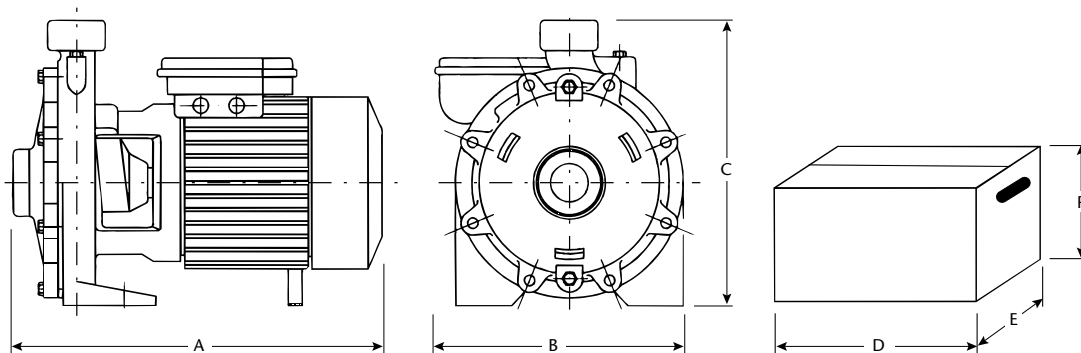
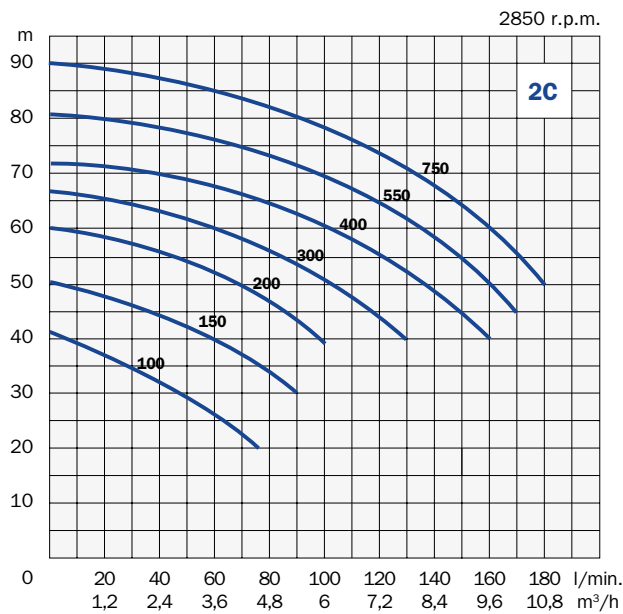

Modello Model Modèle Modell	Aspirazione Suction Aspiration Saug-Seite	Mandata Discharge Refoulement Druck-Seite	Dimensioni - Dimensions - Masstabelle						Peso Weight Poids Gewicht kg
			mm						
			A	B	C	D	E	F	
<b>2C 100</b>	1"1/4 - DN 32	1" - DN 25	344	190	234	370	200	260	16
<b>2C 150</b>	1"1/4 - DN 32	1" - DN 25	376	224	270	390	240	300	24
<b>2C 200</b>	1"1/4 - DN 32	1" - DN 25	376	224	270	390	240	300	25
<b>2C 300</b>	1"1/4 - DN 32	1" - DN 25	376	224	270	390	240	300	26
<b>2C 400</b>	1"1/2 - DN 40	1"1/4 - DN 32	462	265	306	550	300	360	42
<b>2C 550</b>	1"1/2 - DN 40	1"1/4 - DN 32	462	265	306	550	300	360	45
<b>2C 750</b>	1"1/2 - DN 40	1"1/4 - DN 32	462	265	306	550	300	360	46